



West Point City

Public Works Standard Specifications and Drawings

2024

All public works improvements within West Point City shall adhere to the latest Edition of the Manual of Standard Specifications and the latest Edition of the Manual of Standard Plans by the Utah Chapter of APWA unless modified by the latest modification referenced hereafter.

West Point City Overview

- Variances other than what is specifically identified in this document may be allowed or directed in writing by the City Engineer on a case-by-case basis.

Table of Contents

SPECIFICATION MODIFCATIONS	3
City Asphalt Surfacing Requirements	4
Asphalt Surface Treatment – AP4 Asphalt Polymer Surface Treatment	5
West Point Culinary Water System	15
PLAN MODIFICATIONS	37
Road Section Detail	39
Access Management	40
Type A Curb and Gutter Detail.....	41
Cul-de-sac Detail.....	42
Thrust Block Detail	43
Typical Valve Detail.....	43
Typical Trench Section.....	44
UDOT Trench Detail.....	44
Typical Water Connection/Re-connection.....	45
Fire Hydrant detail.....	45
Typical Air Vac Detail	46
Typical Sewer Crossing Detail	47
Multiple Meter Manifold Detail.....	48
1” Water Meter Detail	49
1.5” Water Meter Detail	49
2” Water Meter Detail	50
3” Water Meter Detail	51
3” Water Meter BOM Table	52
4” Water Meter Detail	53
4” Water Meter BOM Table	54
Blow Off Detail.....	55
Canal/UDOT Crossing Detail	56
Sampling Station Detail	57
Street Light Pole Details.....	58
Street Light Master Plan.....	61
Street Sign Standard	62

SECTION 1
SPECIFICATION
MODIFICATIONS

CITY ASPHALT SURFACING REQUIREMENTS

SECTION 32 12 05

1.2 REFERENCES

American Public Works Association (APWA) 2017 Specification or Latest Edition

2.3 ADDITIVES

- A. Mineral Filler:
 - 1. None

- B. Recycle Agent:
 - 2. None

- C. RAP or ROSP (By weight or binder, whichever is lesser):
 - 3. Allowed up to 15%
 - 4. Plant production reports showing the RAP percentage must be reported to the city prior to paving.

2.4 MIX DESIGN

- A. Road Category.
 - 1. III

- B. Mix Designator:
 - 2. 50 Blow

- C. Binder Grade:
 - 3. PG 58-28

- D. Master Grading Band:
 - 4. DM-1/2"

ASPHALT SURFACE TREATMENT - AP4 ASPHALT POLYMER SURFACE TREATMENT

Last Updated: February 01, 2023

DOCUMENT

INCLUDES:

- A. Product Description
- B. References
- C. Quality Assurance
- D. Submittals
- E. Weather
- F. Asphalt Binder
- G. Aggregate
- H. Mix Design
- I. Additives and Dilution
- J. Preparation
- K. Application
- L. Tolerances
- M. Pavement Markings and Paint
- N. Opening to Traffic
- O. Warranty

A. Product Description

AP4 is an asphalt preservation treatment system carefully applied after the pavement is washed clean. AP4 is applied through specialty equipment capable of pre-wetting the pavement and utilizing autonomous rate control. AP4 is a high-performance, high-density, emulsion-based asphalt polymer surface treatment. It consists of cutting-edge polymers for added durability and resistance to ultraviolet rays, oxidation, water, and chemicals. AP4 incorporates industry leading aggregates, providing unmatched mix stability, size gradation, hardness, mineralogy, and chemical compatibility. These characteristics result in unparalleled friction and longevity of the fixative film and AP4 is always manufactured and applied at a minimum of 58% residual solids.

B. References

1. **ASTM/AASHTO/ISSA Standards**
 - a. AASHTO T59 Standard Method of Test for Emulsified Asphalts
 - b. AASHTO T49 Standard Method of Test for Penetration of Bituminous Materials
 - c. AASHTO T51 Standard Method of Test for Ductility of Asphalt Materials
 - d. AASHTO T44 Standard Method of Test for Solubility of Bituminous Materials
 - e. ASTM C128 Standard Method of Test for Relative Density

- f. ASTM C170 Standard Method of Test for Compressive Strength of Dimension Stone
- g. ASTM C114 Standard Method of Test for Dimension Stone (Loss on Ignition)
- h. ASTM D2216 Standard Method of Test for Determining Water Content of Stones by Mass
- i. ASTM C616 Standard Method of Test for Dimension Stone (Determining Moisture Content)
- j. ASTM C2216 Standard Method of Test for Dimension Stone (MOHS Hardness)
- k. ASTM C136 Standard Method of Test for Sieve Analysis of Fine and Coarse Aggregates
- l. ASTM D2172 Standard Method of Test for Quantitative Extraction of Asphalt Binder from Asphalt Mixtures
- m. ASTM D244 Standard Method of Test for Emulsified Asphalt Determining Solids Content
- n. ASTM D95 Standard Method of Test for Determining Density of Asphalt Mixtures
- o. AASHTO T111 Standard Method of Test for Mineral Matter of Ash in Asphalt Materials
- p. ASTM D2196 Standard Method of Test for Rheological Properties
- q. ASTM E70 Standard Method of Test for PH of Aqueous Solutions
- r. ASTM D3960 Standard Method of Test for Determining Volatile Organic Compound Content of Coatings
- s. ASTM D2939 Standard Method of Test for Emulsified Bitumen used as Protective Coatings (Resistant to Re-emulsification)
- t. ISSA TB1000 (Modified) Standard Method of Test for Scrub Resistance of Protective Coatings
- u. ASTM D8099 / D8099M-17, Standard Specification for Asphalt Emulsion Pavement Sealer (Mineral Colloid or Chemically Stabilized Type)

C. Quality Assurance

1. Contractor Quality Control

- a. Ensure equipment is clean and properly serviced according to the owner's manual.
- b. All filtration must be cleaned and spray systems must be flushed with water daily.
- c. Pumps must be routinely serviced and be operating at proper capacity to handle coverage requirements.
- d. Truck or machine must be calibrated prior to each job with proof of documentation.
- e. Every pass with a spray bar must be checked with a wet mil thickness gauge to ensure coverage rate is met.
- f. Edge spraying and cut-in hand spraying must be verified with a mil gauge.
- g. Verify mixture delivered to site contains the same emulsion specified in the mix design.
- h. Reject product that does not meet the requirements in this specification.
- i. On site viscosity, residue, and WPG tests of mix design must be performed for each load.

2. Supplier Quality Control

- a. Use a UDOT qualified laboratory to test materials.
- b. Do not change the source of the asphalt emulsion without supporting changes in the mix design.
- c. Manufacturer must provide a certificate of analysis certifying material is within specification.

D. Submittals

1. **Mix Design:** If required, provide the following and allow the Engineer/Property Engineer the requested time to evaluate the submittal.
 - a. Date of mix design - If older than 60 days, manufacturer must recertify mix design.
 - b. Proportions of aggregate, water, polymer and emulsion in mix.
 - c. Certificate from supplier stating material meets requirements in this document.
 - d. Residual asphalt binder content in pounds per 10 square yards.
 - e. Residual aggregate/mineral solids content in pounds per 10 square yards.
 - f. Total minimum gallons per square yard.
 - g. Thickness target for each application coat in wet mil thickness.
 - h. Results of wet track wear resistance test current within one calendar year of the mix design.
 - i. Results of british pendulum test current within one calendar year of the mix design.
2. **Process:**
 - a. Traffic control plan and communication with residents.
 - b. List of surface preparation steps.
 - c. List steps and methods to cover existing structures (curbs, gutters, manhole, etc) and ensure crisp start and stop lines.
 - d. Process of material application.
3. **Equipment:**
 - a. Surface preparation equipment to be used to achieve 100% removal of dirt and debris on surface and inside pores of the pavement.
 - b. List of rate controlled construction equipment to be used to apply material to edges and center of pavement. List how rate is measured autonomously.
 - c. Spray bar filtration specifications.
4. **Reports:**
 - a. List of (5) projects that have successful product applications on bituminous surfaces, with a minimum of 5 years since application. Include references for each project.
 - b. Source and field quality control testing reports performed by contractor and suppliers.

E. Weather Limitations

1. **Temperature**
 - a. Apply only when pavement and air temperature in the shade is at 55° F and rising.
 - b. Cease application if weather is forecasted to drop below 45° F within 48 hours.
2. **Moisture and wind**

- a. Do not apply on wet pavement, in the rain, 24 hours prior to forecasted rain, or in windy weather.

F. Asphalt Binder

- 1. Perform asphalt emulsion verification in accordance with **UDOT** specification, **Section 02745 AASHTO T59, AASHTO R 5, ASTM D977**
- 2. AP4 meets all requirements in **TABLE 1, 2, 3.**

TABLE 1 - EMULSIFIED ASPHALT PROPERTIES			
CRITERION	STANDARD	MIN	MAX
Sybot Furol Viscosity	AASHTO T59	35	100
Storage Stability 24 Hour, %	AASHTO T59		0.5
Cement Mixing, %	AASHTO T59		2.0
Sieve Test, %	AASHTO T59		0.05
Residue	AASHTO T59	59	63
Particle Charge of Base Emulsion	AASHTO T59	8	
TABLE 2 - RESIDUE FROM DISTILLATION			
CRITERION	STANDARD	MIN	MAX
Penetration, 100g, 5s, dmm	AASHTO T49	50	60
Ductility, (5cm/min.), cm	AASHTO T51	30	
Solubility In Trichloroethylene	AASHTO T44	95.5	
TABLE 3 - POLYMER MODIFIED ASPHALT AND SPECIALTY POLYMERS			
		MIN	MAX
Polymer, Blended Pre-Mill, Percent of Total Asphalt Binder		4%	
Polymer solids content of asphalt binder by weight, added post mill		2%	

High performance polymer additives will be added at an **additional 2%** solids of polymer content, by weight of asphalt binder added post mill to achieve proper mix design, adding bonding properties, improved dried film strength, color retention, flexibility, added UV protection.

G. Aggregate Properties

- 1. Aggregate must meet physical properties of custom aggregate blend.
- 2. Aggregate must be free from organic material and other contaminants. The mineral aggregate must consist of natural crushed stone such as slate, limestone, or sand.
 - a. Total sand in aggregate blend shall not exceed 6% of total aggregate weight.
- 3. Gradation annualized according to **AASHTO T27** on dry weight and percent passing.

TABLE 4 – SLATE PHYSICAL PROPERTIES			
CRITERION	STANDARD	MIN.	MAX.
Specific Gravity	ASTM C128		2.7
Compressive Strength of Dimension Stone	ASTM C170	11,000	
Loss on Ignition at 1000 deg. C, Percent	ASTM C 114		5
Determining Moisture Content, Percent	ASTM D 2216		1
MOHS Hardness	ASTMC 616	6.5	

TABLE 5 –SPECIALITY AGGREGATE PHYSICAL PROPERTIES			
CRITERION	STANDARD	MIN.	MAX.
Specific Gravity	ASTM C128	3.6	
MOHS Hardness	ASTM 616	8	
Bulk Density	-----	100-120 Lbs/cu.ft.	
Absorption %	T185		0.05%
LA Abrasion	AASHTO T 96	5% at 100 revolutions	
Fractured Faces	-----	100%	
Shape	-----	Uniform and angular	

TABLE 6 - GRADATION (A)		
SIEVE	STANDARD	JOB MIX GRADATION BAND
# 8	AASHTO T 27	100
# 16	AASHTO T 27	75-95
# 30	AASHTO T 27	65-85
# 60	AASHTO T 27	40-80
# 100	AASHTO T 27	35-75
# 200	AASHTO T 27	20-50
Slate and Specialty Aggregate blend content %		>40%

NOTES:

(A) Gradation “BAND” analyzed to AASHTO T27 on dry weight and percent passing basis.

H. Mix Design

1. AP4 meets all requirements in **Table 6.**

TABLE 6 - AP4 MIX DESIGN			
CRITERION	STANDARD	MIN.	MAX.

Asphalt Content % by Weight	ASTM D2172	25	30
Solids Content % by Weight	ASTM D244	58	65
Density, Lbs./gal	ASTM D95	10.7	14
Total Inorganic Aggregate % by Weight	AASHTO T111	20	40
Total Sand Content, % by Weight			6

Initial Brookfield Viscosity (Spindle 4 @ 20 RPM)	ASTM D2196	7,500	8,000
Ph	ASTM E70	6	8
Maximum VOC, g/L	ASTM D3960		5
Resistance to Re-emulsification	ASTM D2939	Very-good	
(A) Wet-Track Abrasion six-day soak	ISSA TB100	<80	
Adhesion, PSI	ASTM D7234	>170 PSI	
Low Temperature Flexibility @ 50 Wet Mils Drawdown	1 Inch Mandrel Bend at -10 C	No cracking, flaking, or loss of adhesion to substrate.	
British Pendulum Test Number (a) (b)	ASTM E 303-93	>90 percent of base value	
Dynamic Friction Test Number @ 20 km/h (a) (b)	ASTM E 1911	>90 percent of base value	

Notes:

(a) The British Pendulum Number ratio, or the Dynamic Friction Test Number ratio should indicate that after application of the AP4, the surface retains the required minimum percentage of the original pavement surface test number. Based on a minimum of three (3) measurements per slab. Use value for information only. Value is not to be used for project control.

(b) Only one friction testing method is required. Use either the Dynamic Friction Test or the British Pendulum

Test shown above.

AP4 meets all requirements within ASTM D8099/D8099M Refer to **Table 7**.

TABLE 7 - ASTM D8099/899M-17 MIX PROPERTIES

		ASTM D8099/D8099M-17		AP4	
Property	ASTM Designation	MIN.	MAX.	MIN.	MAX.
Uniformity	D2939	No separation, coagulation, or settlement that cannot be overcome by moderate stirring.		No separation, coagulation, or settlement that cannot be overcome by moderate stirring.	
Wet Film Continuity	D2939	Uniform homogeneous consistency.		Uniform homogeneous consistency.	
Density @25 C 77 F b/MI lbs/gal	D2939	1.0 [9]	1.5 [12]	1.31 [11]	1.37 [11.5]
Residue by Evaporation %	D2939	30	...	59	61
Water Content %	D95	...	70	30	40
Ash Content of Residue %	D2939	10	70	20	40
Drying Time, Film Set, Hours	D2939		8	2	8
Resistance to Heat	D2939	No blistering or slipping.		No blistering or slipping.	
Resistance to Water (A)	D2939	No loss of adhesion, blistering, or tendency to re-emulsify.		1	2
Flexibility (B)	D2939	No flaking, cracking, or loss of adhesion to the substrate.		1	2

Notes:

(A) Report the rating number that describes the condition of the film or description of the film.

- 1 No softening, loss of adhesion, or re-emulsification.
- 2 Slight softening, no loss of adhesion or re-emulsification
- 3 Evidence of softening and loss of adhesion. No re-emulsification. 4 Evidence of softening, loss of adhesion and re-emulsification.

(B) Immediately after bending, examine the coating for cracking. The following crack rating table is to be used for assessment of the film's condition.

- 1 Perfect, no cracks hairline or otherwise, no loss of adhesion.
- 2 Hairline cracks present, no loss of adhesion
- 3 Slight cracking present, no loss of adhesion, hairline cracks may or not be present.
- 4 Moderate cracking and/or loss of adhesion. Slight cracking, hairline cracking, may or may not be present.

I. Additives and Dilution

1. Dilution, additional polymers and aggregate may be added to achieve mix design requirements.
 - a. Use clean potable water that is free from contaminants; a maximum of 5% water for dilution.

J. Asphalt Pavement Surface Preparation

1. Surface Repair

- a. Tack coat on highly absorbent, oxidized, polished, or raveled asphalt.
- b. Crack sealing and patching must be completed before applying the surface treatment application.
- c. Removal of weeds in cracks or joints.
- d. Severe oil spots should be either thoroughly cleaned then treated with an oil spot primer or cut out and patched.
- e. All manholes are to be individually covered to the exact size of collar.

2. Cleaning

- a. Remove loose material, mud, sand, vegetation with high powered brooms/blowers and sweeper trucks.
- b. High pressured water (minimum of 20 GPM @ 4000 PSI) must be used to clean the surface after large debris has been removed. There shall be no dirt or debris on pavement surface or in any pores of the pavement prior to sealing.

K. Application Tolerances

1. A two coat application shall cover a minimum of .40 gallons per square yard (70 wet mils).
2. Two separate application coats are required. The first application coat must be thoroughly set and free from any damp or wet areas before the second application begins.
3. Target application must be applied evenly across first and second coats.
4. Water fogging systems must be used directly ahead of spray application at a rate of .025 gallons per square yard.
5. Keep material delivery at a constant rate.
6. Pump output and truck speed must work autonomously to hit target application rate. Machine output rate control is required.
7. Application on roadways and parking lots must be applied with the use of a spray bar.
8. Triple lap is required as shown:

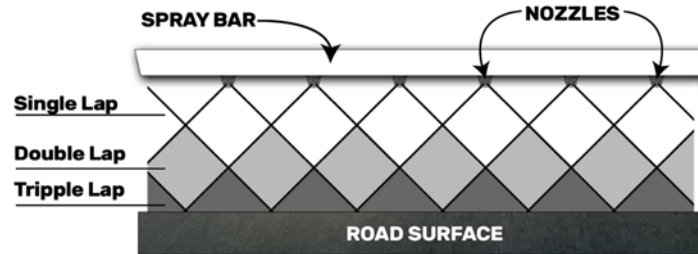

9. Spray nozzles must be evenly spaced and angled as shown:

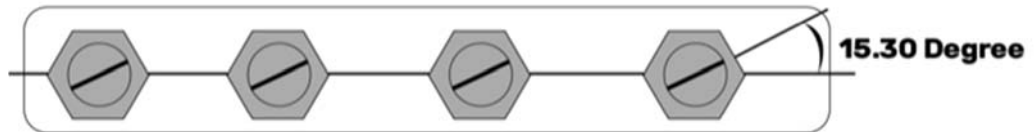

10. If nozzles are square they must be offset as shown:

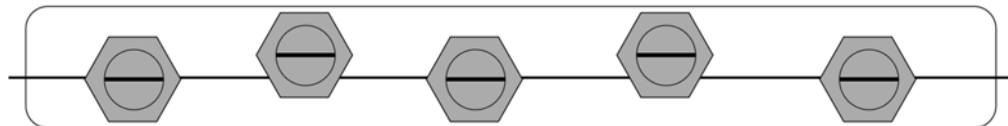

11. Must not reduce application rate along curb edges or around manholes.
12. AP4 must be applied with proper filtration (no clogging tips).
13. Edges must be properly shielded to prevent overspray and provide a clean appearance.
14. Mask all starting and stopping points to provide a clean and square transition.

L. Application Equipment Requirements

1. Spray equipment must have autonomous rate control with pressure sensing technology to allow the operator to precisely control the application rate.
2. Spray bar filtration must have a minimum of 2,000 cubic inches of volume with a minimum of 1,500 square inches of filter face.
3. Spray equipment must have a pavement water fogging system to fog directly ahead of spray pass.
4. Equipment must be able to produce a minimum output of 20,000 square yards daily.

M. Pavement Marking and Paints

1. Do not paint or restripe until AP4 has had ample time to dry.
2. It is recommended to follow paint manufacturers specifications on recommended film thickness, etc.

N. Opening to Traffic

1. Do not open to traffic until AP4 has had ample time to dry, typically 24 hours. Cure time depends on pavement condition, mixture characteristics and weather. Keep traffic off until material does not track out.

O. Warranty

1. Both the contractor and supplier provide a five (5) year minimum written warranty when the existing pavement is in an appropriate condition (contractor and supplier to determine condition). Warranty covers delamination, peeling, and premature wear.
2. Before placement, notify the engineer if pavement condition or application condition voids the warranty.
3. Engineers may allow or cancel product application at no cost to the owner if warranty cannot be given.
4. Acceptable performance after a five (5) year period is no delamination or inter aggregate loss in surface wear. Mechanical disturbances by snow plow chatter, studded tires, etc. are excluded from warranty. Repair defective coverage at no additional cost to the owner.

END OF DOCUMENT

West Point City Culinary Water System

Construction Specifications

SECTION 5. SITE WORK REQUIREMENTS

5.1. Pipeline Trench Excavation and Backfill	Refer to APWA Standard Plans and Specifications (APWA)
5.2. Placement, Removal, and Restoration of Surface Improvements	APWA
5.3. Culinary Waterline and Appurtenances	16
5.4. Disinfection and Testing of Water Lines	APWA
5.5. PVC AWWA C-900 Water Pipe	24
5.6. Ductile Iron Pipe	26
5.7. AWWA C-906 Fused HDPE Piping for Potable Water	29
5.8. Portland Cement Concrete	APWA
5.9. Earthwork	APWA

CULINARY WATERLINE AND APPURTENANCES

SECTION 5.3

5.3.1 DESCRIPTION: The CONTRACTOR shall install all pipe, furnish and install: Valves, valve boxes, fire hydrants, service connects, meter boxes, check valves, air release valves, pipe bedding material; furnish and install all couplings, fittings, bolts, nuts, gaskets, jointing materials, and appurtenances as shown and specified, and as required for a complete and workable piping system.

5.3.1.1.1 GOVERNING DESIGN NOTES: The City is regulated by and intends to adhere to the Utah Division of Drinking Water Rules found in the 100 and 500 series of R309 (DDW Rules). Any conflicts between these written specifications and the DDW Rules shall be resolved by adherence to the more stringent requirements.

5.3.1.1.2 PROTECTING WATER QUALITY: The City does not allow any connection to its system which may jeopardize water quality and integrity. Cross connections are not allowed unless controlled by an approved and properly operating backflow prevention assembly or device. The requirements of the International Plumbing Code and its amendments as adopted by the Department of Commerce shall be met with respect to cross connection control and backflow prevention.

All pipes and pipe fittings installed after January 4, 2014, shall be "lead-free" in accordance with Section 1417 of the federal Safe Drinking Water Act. They shall be certified meeting the ANSI/NSF 372 or Annex G of ANSI/NSF 61.

5.3.1.1.3 DEAD ENDS: To provide increased reliability of service and reduce head loss, dead ends shall be minimized by making appropriate tie-ins whenever practical. Where dead-end mains occur, they shall be provided with a fire hydrant if flow and pressure are sufficient, or with an approved flushing hydrant or blow-off for flushing purposes. Flushing devices shall be sized to provide flows that will give a velocity of at least 2.5 fps in the water main being flushed. No flushing device shall be directly connected to a sewer.

5.3.1.1.4 AIR RELIEF: At high points in water mains where air can accumulate, provisions shall be made to remove air by means of hydrants or air relief valves.

All products incorporated into the project shall be new. All materials and products in contact with culinary water shall be certified compliant with NSF standard 60 or 61, as applicable.

5.3.2 MATERIALS:

5.3.2.1 PVC C-900 PIPE: City standard (Refer to Sec. 5.5, "PVC AWWA C-900 Water Pipe").

5.3.2.2 DUCTILE IRON PIPE: Allowed only on a case-by-case basis with written approval of the City Engineer (Refer to Sec. 5.6, "Ductile Iron Pipe").

5.3.2.3 HDPE PIPE: Allowed only on a case-by-case basis with written approval of the City Engineer (Refer to Sec. 5.7, "AWWA C-906 Fused HDPE Piping for Potable Water").

5.3.2.4 FIRE HYDRANTS: Fire hydrants shall be of a "traffic model" type design conforming to AWWA C-502 Specifications. Hydrants shall be supplied with two 2-1/2-inch and one 4-1/2-inch nozzles. All

nozzles shall have national standard threading. A one cubic yard gravel sump shall be provided at each hydrant for drainage. Fire hydrants shall be Mueller Super Centurion or City-approved equal.

5.3.2.5 ISOLATION VALVES: All main line isolation valves shall conform to Standard AWWA C509 or C515 for Resilient-Seated Gate Valves in line sizes up through 10" or C504 for Rubber-Seated Butterfly Valves in line sizes 12" or larger, unless noted otherwise. All valves shall be designed for 150 psi working pressure or above. The valves shall be mechanical joint unless otherwise indicated on the plans.

5.3.2.6 AIR VALVES: Unless noted otherwise on the plans, air relief valves in the distribution system shall be combination air/vacuum release valves conforming to AWWA C512, Air-Release, Air/Vacuum, and Combination Air Valves for Water and Wastewater Service. Air valves shall be manufactured by A.R.I., USA, San Diego, California, Val-Matic Valve & Mfg. Corp., Elmhurst, Illinois, or approved equal.

5.3.2.7 VALVE BOX AND COVER: All buried valves shall be installed complete with two-piece, cast iron, screw slip, 5-1/4-inch shaft valve box with adjustable height to bring the top of the valve box flush with the ground surface. The valve box and top section shall be from the same manufacturer, intended for use together and within the published dimension tolerances. The valve box shall not be less than 5 inches in diameter and shall have a minimum thickness of 3/16 inch. Valve boxes shall be "Tyler" or equal.

All valve boxes shall be provided with suitable base cover. The word "WATER" shall be cast on the cover.

5.3.2.8 FITTINGS: Fittings shall be ductile iron of the short body design and shall conform to AWWA Standards C-110 or C-153. Fittings inside structures or where otherwise noted on the drawings shall be ANSI Class 125 flanged design with full face rubber gaskets. All exterior surfaces of pipe and fittings shall be coated with a petroleum asphaltic coating.

5.3.2.9 COUPLINGS: Pipe couplings shall be equal to the product of Romac, JCM, Smith-Blair, or Dresser with cast iron couplings being used on all ductile iron pipe. Couplings shall be of the straight, transition, or reducing style as required by the specific installation. All steel fittings shall be coated with a non-oxide coating and bolts shall be coated with a fluoropolymer in accordance with these specifications.

Service lateral couplings, only when lateral couplings are specifically allowed by the City, shall be all brass, with compression x compression end connections.

5.3.2.10 SERVICE SADDLES: Stainless steel, dual strap, nylon-coated with IPS threads, Romac 202NS, SaddleCorp 3450AS PowerJoint or approved equal. Not required on ductile iron pipe when ductile iron pipe is allowed.

5.3.2.11 CORPORATION STOPS: Connections to main lines shall be made through all-metallic ball valve corporation stops with MNPT inlet by CTS compression end connections. Ford FB11003QNL or approved equal.

5.3.2.12 PIPE FOR SERVICE CONNECTIONS: Pipe for water services shall be minimum 3/4" diameter 200 PSI type K copper for potable water service complying with AWWA Standard C800, Underground Service Line Valves and Fittings or SDR 9 CTS HDPE complying with AWWA Standard C901, Polyethylene (PE) Pressure Pipe and Tubing 3/4 In. (19 mm) Through 3 In. (76 mm) for Water Service.

5.3.2.13 METER SETTER ASSEMBLY: A typical meter assembly (5/8 x 3/4) shall consist of a copper setter, 18-inch riser with angle ball valve on the inlet side and Utah State approved dual check valve on the outlet side, Ford VBHC72-18W-44-33-Q-NL or approved equal. Connection to service lines at the base of the setter shall be made with compression connections. The water meter shall be paid for by the customer and supplied and installed by the City.

Non-typical meter assemblies shall be of like construction with equal components and shall be approved by the City inspector.

5.3.2.14 METER BOXES AND LIDS: Meter boxes shall not be located in traffic areas, shall be of the dimensions shown on the standard details, plastic with smooth white interior, manufactured and marketed as a meter box. Mueller Thermal Shell, Hancor meter pit, or approved equal.

Lids for meter boxes shall come with a recess for a Master Meter Allegro-system antenna and a 2" hole ("universal") to accommodate meter reading and shall be cast iron with a lifter worm lock, operated by a large pentagon head bolt. Meter box lids shall be D&L L-2240 or approved equal.

All meter boxes shall be installed and inspected in accordance with the approved drawings.

5.3.2.15 THRUST RESTRAINT: The material for thrust blocks shall be concrete which shall have a compressive strength of no less than 2,000 psi in 7 days. Rebar for valve and vertical elbow tie-downs shall be 60-ksi steel. Mechanical joint restraints shall be compatible with the pipe material on which they will be installed, and of standard manufacture by EBAA Iron, ROMAC or approved equal. Fluoropolymer-coated hardware.

5.3.2.16 UNDERGROUND WARNING TAPE AND LOCATION WIRE: The tape shall be a 2-inch metallic core with a polyethylene cover, blue in color, and have the words "Caution Water Line Buried Below" imprinted on it. The tape shall be Style No. 2WAT as manufactured by Seton Name Plate Company of New Haven, Connecticut, or approved equal. Copper location wire shall be at least #14 plastic coated solid wire.

5.3.2.17 CHECK VALVES: Check valves shall prevent reverse flow in the pipelines. The check valves shall have steel or ductile iron body with bronze trim, stainless steel spring, and resilient seat. The valves shall be Class 125 or better. The check valve shall be manufactured by Val-Matic or approved equal.

5.3.2.18 CONNECTION HARDWARE: Except where otherwise shown or specified, acceptable bolts and nuts are:

- 1) Below grade or subject to high humidity or non-potable submergence: Carbon steel:
 - a) Conforming to the requirements of ASTM A307 Grade A or higher yield and tensile strengths. The corresponding nuts shall conform to ASTM A563 Grade A or higher yield and tensile strengths.
 - b) All bolts and nuts shall be coated with fluoropolymer, TRIPAC 2000 coating system, or approved equal. Anti-seize compound shall not be utilized with the blue nuts.
- 2) Submerged service, potable: Stainless steel:
 - a) Conforming to the requirements of ASTM F593. The corresponding nuts shall conform to ASTM F594.
 - b) Nuts shall be finished with fluoropolymer, TRIPAC 2000 coating system, or approved equal. Anti-seize compound shall not be utilized with the blue nuts.
- 3) Above-grade, non-humid, non-submerged: Carbon steel:

- a) Conforming to the requirements of ASTM A307 Grade A or higher yield and tensile strengths. The corresponding nuts shall conform to ASTM A563 Grade A or higher yield and tensile strengths.
- b) All bolts and nuts shall be zinc plated in accordance with ASTM F1941 (Fe/Zn 5A).
- c) Coatings shall not be applied to nuts or bolts except with the City's written approval.
- 4) Above-grade, weather-exposed, non-submerged: Carbon steel:
 - a) Conforming to the requirements of ASTM A307 Grade A or higher yield and tensile strengths. The corresponding nuts shall conform to ASTM A563 Grade A or higher yield and tensile strengths.
 - b) All bolts and nuts shall be hot-dip galvanized in accordance with ASTM A153.
 - c) Coatings shall not be applied to nuts or bolts except with the City's written approval.

5.3.2.19 SAMPLING STATION: Sampling Stations shall be a meter re-setter design. It is intended to be installed in an existing meter pit in place of the existing meter and the meter is reinstalled in the new re-setter. The sampling point is on the side of the re-setter. Model 1500-5834-NL, WaterPlus Corporation, Pensacola, Florida 32506.

The unit consists of a meter re-setter, a dual check backflow preventer, a quick connect sampling port, and a protective cover for the sampling port and shall be constructed of bronze, brass and copper.

Water samples are taken through the side-mounted quick connect fitting using a Sampling Rod, which is carried from site to site by the operator. The City will provide its own Sampling Rod.

5.3.2.20 BLOW OFF: Permanent (intended for use after construction and commissioning of the water line) blow off valves shall be premanufactured, below-grade, self-draining and non-freezing in standard 5 ¼" valve box with lid labeled "WATER". Blowoffs shall be a Model #TF500 by Kupferle Foundry.

5.3.2.21 BACKFLOW DEVICES: Backflow devices shall be of the type required to mitigate the hazard posed by potential back flow and shall be verified of the correct type by the City's cross connection control program.

Backflow prevention devices (reduced pressure backflow preventers) shall be installed by the developer in accordance with the requirements of the plumbing code. Such devices may be inspected annually by the city public works department.

5.3.2.22 OTHERS: Other materials as specified on the drawings.

5.3.3 CONSTRUCTION:

5.3.3.14 PVC C-900 PIPE: (Refer to Sec. 5.5, "PVC AWWA C-900 Water Pipe").

5.3.3.15 DUCTILE IRON PIPE: (Refer to Sec. 5.6, "Ductile Iron Pipe").

5.3.3.16 HDPE PIPE: (Refer to Sec. 5.7, "AWWA C-906 Fused HDPE Piping for Potable Water").

5.3.3.17 DELIVERY, STORAGE AND HANDLING: Load and unload pipe, fittings, specials, valves, and accessories by lifting with hoists or skidding so as to avoid shock or damage. Do not skid or roll pipe on skidways against pipe already on the ground. Lifting of pipe during unloading and placing into the trench shall be done using two nylon slings placed at the quarter points of the pipe sections. The slings shall bear uniformly against the pipe. Under no circumstances shall the pipe or accessories be dropped into the trench. When not being handled, the pipe shall be supported on timber cradles or on properly prepared ground, graded to eliminate all rock being transported, the pipe shall be supported at all times

in a manner which will not permit distortion or damage to the lining or coating. Any unit of pipe that, in the opinion of the ENGINEER, is damaged beyond repair by the CONTRACTOR shall be removed from the site of the work and replaced with another unit. No payment will be made for damaged pipe or for repairs to such damaged pipe. The use of chains or cables for handling the pipe is not permitted. Each length of pipe shall be unloaded opposite or near the place where it is to be laid in the trench.

5.3.3.18 CONNECTIONS TO EXISTING MAINS: Connections to existing mains shall be made where indicated on the plans. The CONTRACTOR shall determine the exact pipe size and material and provide applicable valves, fittings, and couplings to make a smooth and straight transition into the existing pipeline(s). All connections shall be made and visually inspected by the City for leakage with the line under pressure prior to backfilling. Connections will normally be made with a tee, cross, or other similar type connector.

The CONTRACTOR must uncover the connection area and determine the needs for the connection prior to turning off the water. The water may be turned off Monday through Friday between the hours of 9:00 am and 4:00 pm only, with planned shutdowns starting only on Monday through Thursday. The OWNER must be given 24 hours notice prior to turning off the water to any portion of the system. The CONTRACTOR must make reasonable efforts to avoid disruption of water service.

No interconnection with another drinking water system shall be made without City and State approval.

5.3.3.19 WATER MAINS: Water mains shall be installed in accordance with the AWWA standard for the type of pipe and as may be further referenced in Section 5.3.2. The open ends of all pipelines under construction shall be covered and effectively sealed at the end of the day's work. All mainlines shall terminate with either a fire hydrant or appropriately sized permanent blowoff.

Water mains in public rights-of-way shall be a minimum of 8" nominal diameter.

All water mains installed in non-public rights-of-way (e.g., in easements on private property) and intended for a perpetual transmission line without service lateral connections shall be HDPE as specified in these specifications. City shall be consulted to verify material type and waterline intent prior to installation.

5.3.3.20 FIRE HYDRANTS: All fire hydrants shall be installed with a 1 cubic yard gravel sump and concrete thrust block. See Construction Drawings for thrust blocking. Concrete shall not be placed around joints, bolts, or drain holes. Ensure that drain holes are free to drain to sump. Cover all metal contact areas with a poly wrap material prior to concrete placement. All hydrants shall be installed with the upper safety flange at least 2-1/2 inches and not more than 6 inches above ground level. All hydrants shall be installed with the steamer nozzle facing the street unless otherwise approved by the OWNER.

The location of fire hydrants shall be consistent with the requirements of the State-adopted fire code and as determined by the local fire code official.

Hydrant drains shall not be connected to, or located within, 10 feet of sanitary sewers. Where possible, hydrant drains shall not be located within 10 feet of storm drains.

5.3.3.21 ISOLATION VALVES: The CONTRACTOR shall furnish and install isolation valves at the locations shown on the drawings. The valves shall include either valve and valve box with lid, or valve with hand wheel as indicated on the drawings. The valves shall have flanged or mechanical joint ends, non-rising

stem, O-ring, seals, operating nut and extension as required, or hand wheel, and iron body-bronze resilient seat. The valves shall meet or exceed AWWA Standard C-504 or C-509.

Valves will be inspected, cleaned, set in line, and jointed to pipe with mechanical or flanged joints as indicated on the plans. All mainline valves shall have a concrete base poured in place onto which the valve is anchored against movement by straps on both sides of the valve housing. Steel anchor rods shall be rust-proofed or painted.

Valves shall be located at not more than 500-foot intervals in commercial Cities and at not more than one block or 800-foot intervals in other Cities. Where customers are widely scattered and where future development is not expected, the valve spacing shall not exceed one mile.

At tees and crosses, a valve shall be installed in each main line, out of the intersection, at the extension of property lines.

An exception to the number of valves may be made by the City when following the standard will put main line valves within 250' of each other.

An isolation valve shall be installed in main lines on each end of an easement through private property.

5.3.3.22 AIR VALVES: Air valves shall be located in the main line to evacuate entrapped air, at local high points, or as otherwise called for on the plans. Valves shall be connected to the main line through a tapping saddle. Refer to the City's standard drawings for a typical air valve installation detail.

5.3.3.23 VALVE BOX AND COVER: All buried valves shall be installed complete with two-piece, cast iron, 5-1/4-inch shaft valve box with locking lid. The lid shall have the work "WATER" cast in the metal. Valves and valve boxes shall be installed where shown on the drawings. Valves and valve boxes shall be set plumb. Valve boxes shall be centered directly over the valve. Valves shall be aligned with property lines where possible. Earth fill shall be carefully tamped around the valve box to a distance of 4 feet on all sides of the box, or to the undisturbed trench face if less than 4 feet. Valve boxes shall have the interiors cleaned of all foreign matter before installation.

All valve boxes located in streets shall be installed as nearly to grade as possible. After the pavement is in place, the valve boxes shall be raised to grade, the surrounding asphalt shall be neatly cut to form a circular opening 2 feet and 6 inches in diameter with the valve box centered, and a concrete collar shall be cast around the box. Valve boxes and collars in off-road areas shall extend 2 inches above grade.

When the valve box is in a roadway with posted speeds over 40 MPH, an extra deep valve box cover shall be installed.

5.3.3.24 FITTINGS: Bends, tees, reducers, flange adapters, and adaptor couplings shall be inspected, cleaned, and jointed to pipe as specified by the manufacturer. Reaction or thrust blocking shall be applied at bends of 11-1/4 degrees and more, at plugs, caps, and at tees.

5.3.3.25 COUPLINGS: Couplings shall be installed where connecting two segments of pipe of the same nominal diameter in the same alignment, when repairing or making final connections. Mechanical restraint shall be provided at the coupling if the two pipes are different nominal diameters.

5.3.3.26 WATER SERVICE CONNECTIONS: Make service connections in conformance with the State-adopted plumbing code and local jurisdictional standards through a service saddle and install service lines as shown on the Construction Drawings, or as directed by the OWNER's representative. Use teflon

tape on all taps. Locate service taps in the upper quadrant of the main line, approximately 45 degrees. The minimum distance between taps is 24 inches, with a 5 degree stagger. Do not make service taps within 24 inches of the end of the main line.

Excavate and backfill in accordance with APWA Plans 381 and 382 and related APWA specifications. All work must be inspected by the City prior to backfilling. Pressure test all services before backfilling. Make no service connections until main line is fully accepted by the OWNER. Extend service line to meter and 5 feet beyond meter and plug as indicated on the contract drawings. Service lines shall be capped until connected for service.

Install a tracer wire with all service laterals. Ensure physical and electrical connectivity with the wire at the mainline. The wire shall be terminated with a neatly wound coil at least 4 feet long in the meter box, with the end secured between the meter box and ring. All meter setter assemblies shall be no more than 20 inches and not less than 18 inches from finish ground level. The water meter shall be paid for by the customer and supplied and installed by the City.

Each meter box within 20' of another meter box, identify unit being served. Furnish and install a 304 or 316 stainless steel tag stamped with House/Building # and if needed for further identification, the Unit # being served by the meter. Text shall be no less than 1/4" tall on a tag no less than 2" x 2", no less than 0.040" thick. Secure with SS tie to meter setter.

Service saddle and meter box shall be located by the City with GPS before backfilling. Record station of service connection to main line and record location and depth of end of service line, tying distances to at least two surface landmarks. Sketch information on an 8-1/2 x 11 inch form and record any particular problems and submit to City Inspector before demobilizing from site.

All meter boxes shall be protected against wind entry at the box/lid interface by placing and compacting well graded, clean, earthen material to a depth of 12 inches below the top of the lid, extending at least 12 inches radially from the meter box.

Individual booster pumps shall not be allowed for individual service from the public water supply mains. Exceptions to the rule may be granted by the State if it can be shown that the granting of such an exception will not jeopardize the public health.

5.3.3.27 THRUST RESTRAINT: Thrust blocks shall be provided at reducers and valves where shown on the drawings, at all tees, plugs, and caps, and at bends deflecting 11-1/4 degrees or more.

Reinforcement bar shall be pre-bent before placement around valve or elbow, then temporarily spread apart for installation. Form hooks in both ends of rebar to extend completely under the valve or fitting.

Thrust blocks shall be placed between solid ground and the fitting to be anchored; the area of bearing on the pipe and on the ground in each instance shall be that shown on the drawings. The block shall, unless otherwise shown or directed, be so located as to contain the resultant thrust force and so that the pipe and fitting joints will be accessible for repair.

Mechanical thrust restraints shall also be used at all locations where thrust blocks are called for.

Mechanical thrust restraints, fittings and connection hardware shall be securely wrapped with 8 mil or greater polywrap and taped to prevent contact with concrete.

5.3.3.28 UNDERGROUND WARNING TAPE AND LOCATION WIRE: The CONTRACTOR shall furnish and install an underground warning tape as the trench is backfilled. The tape shall be placed directly over the waterline and to a depth of 24 inches below the finished ground surface.

A copper trace wire shall be in the bottom of the main line or service lateral pipe trench (when a new service lateral is pulled through an existing lateral, a tracer wire shall also be pulled with the new lateral) and accessible from the surface at each valve box including blowoffs (bring the wire up the outside of the bottom of each box and bring it inside the top section) and at each fire hydrant. At fire hydrants, neatly coil 4' of trace wire around the hydrant barrel below the traffic flange.

All mainline trace wires must be interconnected in intersections, at mainline tees and mainline crosses. At tees, the three wires shall be joined using a single 3-way lockable connector. At crosses, the four wires shall be joined using a 4-way connector. Use of two 3-way connectors with a short jumper wire between them is an acceptable alternative. Direct bury wire connectors – shall include 2- and 3-way lockable connectors and mainline to lateral lug connectors specifically manufactured for use in underground trace wire installation. Connectors shall be dielectric silicon filled to seal out moisture and corrosion and shall be installed in a manner to prevent any uninsulated wire exposure. Non- locking friction fit, twist on or taped connectors are prohibited.

5.3.3.29 SEPARATION OF WATER MAINS FROM SANITARY SEWER: The horizontal distance between pressure water mains and sanitary sewer lines shall be at least ten feet. Where a water main and a sewer line must cross, the water main shall be at least 18 inches above the sewer line. Separation distances shall be measured edge-to-edge (i.e. from the nearest edges of the facilities). Water mains and sewer lines shall not be installed in the same trench. When a new sewer force main crosses under an existing water main, all portions of the sewer force main within 10 feet (horizontally) of the water main shall be enclosed in a continuous sleeve. Where local conditions make it impossible to install water or sewer lines at the separation distances required above, an exception to the standard may be possible. The entity seeking the exception shall initiate and pursue a request for a separation exception with the State Division of Drinking Water, in accordance with R309-550-7 of the State of Utah Administrative Rules.

When a new water main crosses over an existing sewer force main, the water main shall be constructed of pipe materials with a minimum rated working pressure of 200 psi or equivalent pressure rating.

5.3.3.30 BLOW OFF: A permanent blow off meeting City standards shall be installed at all dead-end main lines that otherwise do not terminate at a fire hydrant.

5.3.3.31 SAMPLING STATION: One sampling station shall be installed in each new development or phase thereof, as determined by the City Engineer.

5.3.3.32 BACKFLOW DEVICES: Installation of Backflow devices shall conform to the State-adopted plumbing code.

5.3.4 MEASUREMENT AND PAYMENT: As specified in Section 1.4 of the Contract Documents.

End of Section

PVC AWWA C-900 WATER PIPE

SECTION 5.5

5.5.1 DESCRIPTION: The work includes providing and installing PVC water pipe with integral bell and spigot joints. All pipes and fittings shall be lead free, meeting the requirements of ANSI/NSF 372 or Annex G of ANSI/NSF 61.

Note: All new culinary water main lines in the City shall be PVC unless directed otherwise by the City Engineer.

5.5.2 MATERIALS:

5.5.2.1 PIPE: Pipe shall comply with the latest version of AWWA Standard C-900, with material compound being 12454A, per ASTM D1784. Pipe shall be DR18 with a minimum diameter of 8" unless shown otherwise on the plans.

5.5.2.2 JOINTS: The Elastomeric Seal (gasket) shall conform to ASTM F477. The gasketed joint assembly shall conform to ASTM D3139, and the installation of the C900 pipe shall conform to Uni-Bell-3, AWWA M23 installation guide.

5.5.2.3 FITTINGS: Fittings shall be cast iron or ductile iron, iron pipe size for PVC application, and in accordance with AWWA C-110 (flanged fittings) or AWWA C-153 (MJ fittings). They shall be capable of withstanding, without bursting, hydrostatic tests of three times the rated water working pressure. The fittings shall be furnished with gasketed mechanical- or flange-joint conforming to AWWA C-111.

5.5.2.4 SERVICE CONNECTIONS: Service connections to PVC plastic pressure pipe shall be by nylon coated, ductile iron, double stainless-steel strap service saddles, Romac 202NS, or approved equal specifically designed for type of mainline pipe.

5.5.2.5 QUALITY ASSURANCE: Each standard and random length of pipe is to be tested to three times the class pressure of the pipe for a minimum of 5 seconds. The integral bell is to be tested with the pipe. Randomly selected samples shall be tested in accordance with ASTM D1599 to withstand, without failure, pressures listed below when applied in 60 to 70 seconds: DR-18, a minimum burst pressure of 775 PSI; DR-14, a minimum burst pressure of 985 psi.

5.5.3 CONSTRUCTION:

5.5.3.1 INSTALLATION: The trench bottom shall be stable, smooth and free of frozen material, clodded dirt, and stones over 3/4 inch in diameter. Bell holes should be provided at each joint for easier assembly and uniform support. Large rocks must be removed to provide 6 inches clearance in all directions from pipe and accessories. The pipe shall be installed with proper bedding providing uniform support under the pipe. Backfill materials shall be worked under the pipe to provide adequate haunching. Initial backfill material should be placed to a minimum of 12 inches over the pipe. All pipe embedment material shall be selected and placed carefully, avoiding stones over 3/4-inch, frozen lumps, and debris.

5.5.4 MEASUREMENT AND PAYMENT Section 1.4.9 takes precedence over the following if there is a discrepancy between the two sections.

PVC pipe measurement shall be per lineal foot installed piping of the type, size and class shown on the drawings and in the bidding schedule (payment shall be made as part of another Bid Item if PVC pipe is not specifically included as a bid item). Measurement shall be along the centerline of the pipe as measured in the field following construction. No deduct in length for payment will be made for valve & fittings.

Payment will be made per Bid Item only after the surface restoration, including, but not limited to, gravel and asphalt restoration, has been completed and accepted.

Payment to install pipelines shall be at the unit price in the Bid Schedule. Payment shall be full compensation for mobilization, cutting asphalt pavement; unclassified excavation; trench backfill when excavated materials are suitable when determined in consultation with the City inspector (when needed, suitable trench backfill material shall be imported, placed and compacted under a separate bid item), location tape; tracer wire, storing and installing the pipe, fittings, elbows and couplings not specifically identified as a separate bid item; removal and disposal of excess or rejected excavated materials; thrust blocks; pressure testing; disinfecting, dechlorination, flushing and other materials, equipment and labor related to placing the line into service that are not specifically mentioned in this or other bid items. Payment shall also include compensation for restoration of miscellaneous improvements damaged during construction.

End of Section

DUCTILE IRON PIPE

SECTION 5.6

5.6.1 DESCRIPTION: This section covers the requirements for ductile iron pressure pipe materials, installation and inspection. All pipes and fittings shall be lead free, meeting the requirements of ANSI/NSF 372 or Annex G of ANSI/NSF 61.

Note: All new culinary water main lines in the City shall be PVC unless directed otherwise by the City Engineer.

5.6.2 MATERIALS:

5.6.2.1 DUCTILE IRON PIPE: Ductile iron pipe shall conform to all requirements of AWWA C-151 and ANSI A-21.51 "Ductile Iron Pipe, Centrifugally Cast in Metal Molds or Sand Lined Molds, For Water or Other Liquids." Minimum pressure class shall be 250 PSI.

5.6.2.2 JOINTS:

- **MECHANICAL JOINTS:** All mechanical joints shall meet requirements of ANSI A-21.6 and ANSI 21.11. All gaskets surfaces shall be smooth and free from imperfections. All mechanical joint gaskets shall be less than one year old. Bolts shall meet all requirements of the above specifications, honoring all characteristics, tolerances, and tests. All bolts shall be of the proper size and length to match the size of pipe fitting as per drawings.
- **PUSH-ON JOINTS:** Push-on joints shall be used for main line ductile iron pipe for this project. All push-on joints shall meet the requirements of ANSI 21.11. Gaskets shall be free from defects and not over one year old. Lubricants shall be non-toxic and have no deteriorating effects on gasket materials. It shall not impart taste, odor or flavor to water in a pipe.
- **FLANGED JOINTS:** Flanged joints shall be bolted firmly with machine, stud or cap bolts of proper size. Flanges may be cast integrally with the pipe or may be screwed or threaded pipe. Flanges shall be faced and drilled and of proper dimensions and class, for size and pressure required. All flanges shall meet requirements of ANSI A 21.10, "American National Standard for Ductile Iron and Gray Iron Fittings."

Bolts and nuts, unless otherwise specified, shall be meet the requirements of 5.3.2.16. Bolts will be provided with standard hexagonal nuts and standard hexagonal heads. Bolts shall be of the diameter required for each flange and, when installed, shall be of length so that no more than 3/8 inch or less than 1/8 inch extends past face of nut. Gaskets shall be 1/16 inch thick, made of best quality sheet gasket material or equal and be certified to meet the requirements of NSF Standard 61. A gasket for each flange joint of proper size, ring type or full face shall be installed.
- **COMPRESSION JOINTS:** Compression joints shall be mechanical joint cast iron sleeve with armor guard gaskets, Rockwell 441 or Flange adaptor Rockwell Type 900 or approved equal, as specified on approved drawings.

5.6.2.3 FITTINGS:

- **MECHANICAL JOINT FITTINGS:** Mechanical Joint Fittings shall conform to ANSI A 21.10, "American National Standard for Ductile Iron and Gray Iron Fittings."
- **PUSH-ON FITTINGS:** Push-on fittings shall conform to ANSI A 21.10 with bells, sockets, and plain ends per ANSI A 21.11.
- **FLANGED FITTINGS:** Flanged fittings shall conform to ANSI 21.10.
All flanges shall be faced and drilled. Where cap screws or stud bolts are needed, flanges shall be tapped to support cap screws or stud bolts as per approved drawings.

5.6.2.4 CEMENT MORTAR LINING: Ductile iron pipe and fittings shall be lined with cement mortar in accordance with the requirements of the "American National Standard for Cement Mortar Lining for Cast Iron and Ductile Iron Pipe and Fittings for Water" (ANSI A21.4 AWWA C104).

5.6.2.5 ASPHALTIC COATING: Ductile iron pipe shall be supplied with an exterior asphaltic coating approximately 1 mil thick per applicable AWWA standards for ductile iron pipe and fittings, EXCEPT THAT all pipe and fittings installed above grade or in pipe galleries shall be supplied without an asphaltic coating or otherwise prepared for a primer and 2 coats of durable epoxy coating.

5.6.2.6 INTERIOR PIPING COATING: All interior piping shall be prepared for and coated with a suitable primer and at least 2 coats of liquid epoxy to a DFT of at least 10 mil. TNEMEC N140 or equal. Color as determined by Owner.

5.6.2.7 COATING OF PIPES INSIDE STORAGE TANKS: Pipe inside storage tanks shall NOT have a coal tar coating on the exterior, but shall be externally coated with a two-part epoxy at least 12 mil DFT, meeting the requirements of NSF Standard 61. TNEMEC N140 or equal. Interior lining shall be the same as specified in 5.6.2.4 above.

5.6.3 CONSTRUCTION:

5.6.3.1 INSTALLATION: Ductile iron pipe shall be installed in accordance with the "Installation of Ductile Iron Mains and Their Appurtenances" (ANSI/AWWA C600).

Tees, elbows, crosses, and reducers shall be used for changes in direction and outlets, unless otherwise specified on the drawings.

Anchors, thrust bolts, thrust blocks and mechanical joint restraints shall be placed at valves, elbows, tees, etc., as shown on the approved drawings or as directed by the ENGINEER.

All ductile iron pipe installation shall proceed on a stable foundation, with joints closely and accurately fitted. Joints shall be clean and dry, and a non-toxic joint lubricant, as recommended by the pipe supplier, shall be applied uniformly to the mating joint and gasket surfaces to facilitate easy, positive joint closure.

All pipe shall be installed with uniform bearing under the full length of the barrel, with suitable excavations being made to receive pipe bells and fittings.

Bedding material shall be compacted around the pipe to firmly bed the pipe in position. If adjustment of position of a pipe length is required after being laid, it shall be removed and rejoined as for new pipe installation. In addition to the above requirements, all pipe installation shall comply with the specific requirements of the pipe manufacturer.

Each pipe shall be laid true to line and grade and in such a manner as to form a close concentric joint with adjoining pipe and to prevent sudden offsets to the flow line. All joint offsets shall be made as specified in AWWA Standard for "Installation of Water Mains", C600. As work progresses, the interior of the pipe shall be cleared of dirt and superfluous materials. Where cleaning after laying is difficult because of small pipe size, a suitable swab or drag shall be kept in the pipe and pulled forward past each joint immediately after jointing as set, and pipe shall not be laid when conditions of the trench or weather is unsuitable for such work. At all times when work is in progress, all open ends of the pipe and fittings shall be securely closed to the satisfaction of the ENGINEER, so that no water, earth, or other substance will enter the pipe or fittings.

5.6.3.2 MEASUREMENT AND PAYMENT: Section 1.4.9 takes precedence over the following if there is a discrepancy between the two sections.

Ductile iron pipe measurement shall be per lineal foot installed piping of the type, size and class shown on the drawings and in the bidding schedule. Measurement shall be along the centerline of the pipe as measured in the field following construction. No deduct in length for payment will be made for valve fittings, manholes or structures.

Payment will be made per Bid Item only after the surface restoration, including gravel and asphalt restoration, has been completed and accepted.

Payment to install pipelines shall be at the unit price in the Bid Schedule. Payment shall be full compensation for mobilization, traffic control signs, devices and flag persons; cutting asphalt pavement; unclassified excavation; imported material for pipe bedding; trench backfill; location tape; storing and installing the pipe, fittings, elbows and couplings; removal and disposal of excess or rejected excavated materials; compaction; thrust blocks; pressure testing; and disinfecting, flushing and placing the line into service. Payment shall also include compensation for restoration of miscellaneous improvements damaged during construction.

No classification of excavated materials shall be made other than solid rock requiring blasting. Excavation shall include the removal and subsequent handling of all water, earth, shale, loose or cemented gravel, loose rock, and other materials of whatsoever nature excavated or otherwise removed in the performance of contract work.

End of Section

AWWA C-906 FUSED HDPE PIPING FOR POTABLE WATER

SECTION 5.7

5.7.1 General Terms and Conditions

5.7.1.1 Scope. This specification covers requirements for PE 4710 high-density polyethylene piping for potable water distribution and transmission mains. All pipes and fittings shall be lead free, meeting the requirements of ANSI/NSF 372 or Annex G of ANSI/NSF 61. All work shall be performed in accordance with these specifications.

Note: All new culinary water main lines in the City shall be PVC unless directed otherwise by the City Engineer.

5.7.1.2 Engineered and Approved Plans. Potable water distribution and transmission main construction shall be performed in accordance with engineered construction plans for the work prepared under the direction of a Professional Engineer.

5.7.1.3 Referenced Standards. Where all or part of a Federal, ASTM, ANSI, AWWA, etc., standard specification is incorporated by reference in these Specifications, the reference standard shall be the latest edition and revision.

5.7.1.4 Licenses and Permits. A licensed and bonded Contractor shall perform all potable water distribution and transmission main construction work. The Contractor shall secure all necessary permits before commencing construction.

5.7.1.5 Inspections. All work shall be inspected by an Authorized Representative of the Owner who shall have the authority to halt construction if, in his opinion, these specifications or standard construction practices are not being followed. Whenever any portion of these specifications is violated, the Project Engineer or his Authorized Representative, shall, by written notice, order further construction to cease until all deficiencies are corrected. A copy of the order shall be filed with the Contractor's license application for future review. If the deficiencies are not corrected, performance shall be required of the Contractor's surety.

5.7.1.6 Submittals. Pipe specifications, stamping description, manufacturer's recommended joining procedures and certification of fusing technicians by pipe manufacturer as having fused, or been trained to fuse, pipe of the size specified within the 6 months preceding the commencement of work under this contract.

5.7.2 Polyethylene Pipe and Fittings

5.7.2.1 Qualification of Manufacturers. The Manufacturer shall have manufacturing and quality assurance facilities capable of producing and assuring the quality of the pipe and fittings required by these Specifications. The Manufacturer's production facilities shall be open for inspection by the Owner or his Authorized Representative. The ENGINEER shall approve qualified Manufacturers.

5.7.2.2 Materials. Black PE materials used for the manufacture of polyethylene pipe and fittings shall be PE 3408 or 4710 high density polyethylene meeting ASTM D 3350 cell classification 345464C or 445574C, respectively, and shall be listed in the name of the pipe and fitting Manufacturer in PPI (Plastics Pipe Institute) TR-4 with a standard grade HDB rating of 1600 psi at 73°F. Color material, when used, shall be the same except for meeting ASTM D 3350 cell classification 345464E. The material shall be listed and approved for potable water in accordance with NSF Standard 61. When requested on the order, the Manufacturer shall certify that the materials used to manufacture pipe and fittings meet these requirements.

5.7.2.3 Interchangeability of Pipe and Fittings. The same Qualified and Approved Manufacturer shall produce polyethylene pipe and fittings. Products such as fittings or flange adapters made by sub-contractors or distributors are prohibited.

5.7.2.4 Polyethylene Pipe. Polyethylene pipe shall be manufactured in accordance with AWWA C901-96 for sizes 1-1/4" thru 3" IPS diameters and to the requirements of ASTM D3035. Pipe 4" IPS and DIPS sizes 4" and above shall be manufactured to the requirements of ASTM F714 and AWWA C906-99.

5.7.2.5 Optional Service Identification Stripes for IPS Sized Pipe. IPS pipes shall be black. When requested as an option, IPS pipes shall have four, equally spaced, blue color stripes co-extruded into the pipe outside surface. Stripes printed on the pipe outside surface shall not be acceptable.

5.7.2.6 Service Identification Stripes for DIPS Sized Pipe. DIPS sized pipes shall have three equally spaced pairs of longitudinal blue color stripes co-extruded into the pipe outside surface. Stripes printed on the outside surface shall not be acceptable.

5.7.2.7 Optional Color Shell. When requested as an option, a blue color shell co-extruded into the pipe outer surface shall permanently identify IPS or DIPS pipes.

5.7.2.8 Polyethylene Fittings & Custom Fabrications. Polyethylene fittings and custom fabrications shall be molded or fabricated by the Approved Pipe Manufacturer. All fittings and custom fabrications shall be pressure rated for the same internal pressure rating as the mating pipe.

5.7.2.9 Molded Fittings. Molded fittings shall be manufactured and tested in accordance with ASTM D 3261 and shall be so marked. Molded fittings shall be tested in accordance with AWWA C906.

5.7.2.9.1 X-Ray Inspection. The Manufacturer shall submit samples from each molded fittings production lot to x-ray inspection.

5.7.2.10 Fabricated Fittings. Fabricated fittings shall be made by heat fusion joining specially machined shapes cut from pipe, polyethylene sheet stock or molded fittings. Fabricated fittings shall be rated for internal pressure service at least equal to the full service pressure rating of the mating pipe. Fabricated fittings shall be tested in accordance with AWWA C906.

5.7.2.11 Polyethylene Flange Adapters. Flange adapters shall be made with sufficient throughbore length to be clamped in a butt fusion-joining machine without the use of a stub-end holder. The sealing surface of the flange adapter shall be machined with a series of small v-shaped grooves (serrations) to promote gasketless sealing, or restrain the gasket against blowout.

5.7.2.12 Back-up Rings & Flange Bolts. Flange adapters shall be fitted with back-up rings that are pressure rated equal to or greater than the mating pipe. The back-up ring bore shall be chamfered or radiused to provide clearance to the flange adapter radius. Flange bolts and nuts shall be Grade 3 or higher.

5.7.2.13 MJ Adapters. MJ Adapters 4" thru 16" may be provided with optional Stainless Steel Stiffener upon request. MJ Adapters 14" and above shall be provided with Heavy Duty Back-up Ring Kits. All MJ adapters 18" and above must be provided with Stainless Steel stiffeners.

5.7.2.14 Compliance Tests. Manufacturer's inspection and testing of the materials. In case of conflict with Manufacturer's certifications, the Contractor, Project Engineer, or Owner may request retesting by the Manufacturer or have retests performed by an outside testing service. All retesting shall be at the requestor's expense and shall be performed in accordance with these Specifications.

5.7.3 Joining

5.7.3.1 Heat Fusion Joining. Joints between plain end pipes and fittings shall be made by butt fusion. Joints between the main and saddle branch fittings shall be made using saddle fusion. The butt fusion and saddle fusion procedures used shall be procedures that are recommended by the pipe and fitting Manufacturer. The Contractor shall ensure that persons making heat fusion joints have received training in the Manufacturer's recommended procedure. The Contractor shall maintain records of trained personnel, and shall certify that training was received not more than 6 months before commencing construction. External and internal beads shall not be removed.

5.7.3.1.1 **Butt Fusion of Unlike Wall Thickness.** Butt fusion shall be performed between pipe ends, or pipe ends and fitting outlets that have the same outside diameter and are not different in wall thickness by more than one Standard DR, for example, SDR 13.5 to SDR 17, or SDR 11 to SDR 13.5. Transitions between unlike wall thickness greater than one SDR shall be made with a transition nipple (a short length of the heavier wall pipe with one end machined to the lighter wall) or by mechanical means or electrofusion. SDR's for polyethylene pipe are 7.3, 9, 11, 13.5, 17, 21, 26, 32.5 and 41.

5.7.3.1.2 **Heat Fusion Training Assistance.** Upon request and at the requestor's expense, training personnel from the Manufacturer or his Representative shall be made available.

5.7.3.2 Joining by Other Means. Polyethylene pipe and fittings may be joined together or to other materials by means of (a) flanged connections (flange adapters and back-up rings), (b) mechanical couplings designed for joining polyethylene pipe or for joining polyethylene pipe to another material, (c) MJ Adapters or (d) electrofusion. When joining by other means, the installation instructions of the joining device manufacturer shall be observed.

5.7.3.2.1 **ID Stiffener and Restraint.** A stiffener shall be installed in the bore of the polyethylene pipe when an OD compression mechanical coupling is used and when connecting plain end PE pipe to a mechanical joint pipe, fitting or appurtenance. External clamp and tie rod restraint shall be installed where PE pipe is connected to the socket of a mechanical joint pipe, fitting or appurtenance except where an MJ Adapter is used.

5.7.3.3 Branch Connections. Branch connections to the main shall be made with saddle fittings or tees. Polyethylene saddle fittings shall be saddle fused to the main pipe per 3.1.

5.7.4 Installation

5.7.4.1 General. When delivered, a receiving inspection shall be performed and any shipping damage shall be reported to the manufacturer within 7 days. Installation shall be in accordance with ASTM D 2774, Manufacturer's recommendations and this specification. All necessary precautions shall be taken to ensure a safe working environment in accordance with all applicable safety codes and standards.

5.7.4.2 Excavation. Trench excavations shall conform to the plans and drawings, as authorized in writing by the Project Engineer or his Approved Representative and in accordance with all applicable codes. The Contractor shall remove excess groundwater. Where necessary, trench walls shall be shored or reinforced, and all necessary precautions shall be taken to ensure a safe working environment.

5.7.4.3 Large Diameter Fabricated Fittings. Not more than one plain-end connection of 16" IPS and larger fabricated directional fittings (elbows, tees, etc.) shall be butt fused to the end of a pipe length before placing the assembly into the trench. The remaining fitting connections shall be made in the trench using butt fusion, flange or other connection means in accordance with 3.2. Flange and other mechanical connections shall be assembled, and tightened in accordance with the connection manufacturer's instructions and 4.4. Handling, lifting, moving or lowering a 16" IPS or larger fabricated fitting that is connected to more than one pipe length is prohibited. The installing contractor at his expense shall correct fitting damage caused by such improper handling.

5.7.4.4 Mechanical Joint & Flange Installation. Mechanical joint and flange connections shall be installed in accordance with the Manufacturer's recommended procedure. Primed ductile iron backup rings shall be furnished and installed at all connections permitting such. MJ Adapters and flanges shall be centered and aligned to the mating component before assembling and tightening bolts. In no case shall MJ gland or flange bolts be used to draw the connection into alignment. Bolt threads shall be lubricated, and flat washers should be used under the nuts. Bolts shall be evenly tightened according to the tightening pattern and torque step recommendations of the Manufacturer. At least 1 hour after initial assembly, flange connections shall be re-tightened following the tightening pattern and torque step recommendations of the Manufacturer. The final tightening torque shall be as recommended by the Manufacturer. Bolts, nuts and washers shall be stainless steel and shall be liberally coated with a rubberized undercoating prior to placing backfill.

5.7.4.5 Foundation & Bedding. See Section 5.1, PIPELINE TRENCH EXCAVATION AND BACKFILL.

5.7.4.6 Pipe Handling. When lifting with slings, only wide fabric choker slings capable of safely carrying the load shall be used to lift, move, or lower pipe and fittings. Wire rope and chain are prohibited. Slings shall be of sufficient capacity for the load, and shall be inspected before use. Worn or damaged equipment shall not be used.

5.7.4.7 Backfilling. See Section 5.1, PIPELINE TRENCH EXCAVATION AND BACKFILL. During embedment placement and compaction, care shall be taken to ensure that the haunch areas below the pipe springline are completely filled and free of voids.

5.7.4.8 Protection against shear and bending loads. In accordance with ASTM D 2774, connections shall be protected where an underground polyethylene branch or service pipe is joined to a branch fitting such as a service saddle, branch saddle or tapping tee on a main pipe, and where pipes enter or exit casings or walls. The area surrounding the connection shall be embedded in properly placed, compacted backfill, preferably in combination with a protective sleeve or other mechanical structural support to protect the polyethylene pipe against shear and bending loads.

5.7.4.9 Final Backfilling. See Section 5.1, PIPELINE TRENCH EXCAVATION AND BACKFILL.

Testing.

5.7.4.10 Fusion Quality. The Contractor shall ensure the field set-up and operation of the fusion equipment, and the fusion procedure used by the Contractor's fusion operator while on site. Upon request by the Owner, the Contractor shall verify field fusion quality by making and testing a trial fusion. The trial fusion shall be allowed to cool completely; then test straps shall be cut out and bent strap tested in accordance with ASTM D 2657. If the bent strap test of the trial fusion fails at the joint, the field fusions represented by the trial fusion shall be rejected. The Contractor at his expense shall make all necessary corrections to equipment, set-up, operation and fusion procedure, and shall re-make the rejected fusions.

5.7.4.11 Hydrostatic Leak Testing. This hydrostatic leak test procedure consists of filling, an initial expansion phase, a test phase, and depressurizing. There are two alternatives for the test phase. Leak testing shall be observed by the OWNER or ENGINEER.

5.7.4.11.1 Filling. Fill the restrained test section completely with water.

WARNING – Ensure that there is no air trapped in the test section. Failure with entrapped air can result in explosive release and result in death or serious bodily injury. Use equipment vents at high points to remove air.

5.7.4.11.2 Initial Expansion Phase. Gradually pressurize the test section to test pressure, and maintain test pressure for three (3) hours. During the initial expansion phase, polyethylene pipe will expand slightly. Additional test liquid will be required to maintain pressure. It is not necessary to monitor the amount of water added during the initial expansion phase.

5.7.4.11.3 Test Phase – Alternate 1. Immediately following the initial expansion phase, reduce test pressure by 10 psi, and stop adding test liquid. If test pressure remains steady (within 5% of the target value) for one (1) hour, no leakage is indicated.

5.7.4.11.4 Test Phase – Alternate 2. This alternative is applicable when the test pressure is 150% of the system design pressure.

Immediately following the initial expansion phase, monitor the amount of make-up water required to maintain test pressure for one (1), or two (2), or three (3) hours. If the amount of make-up water needed to maintain test pressure does not exceed the amount given below, no leakage is indicated.

<i>Make-Up Water Allowance for Test Phase – Alternate 2, (U.S. Gal/100 ft of pipe)</i>			
<i>Nominal Pipe size (in.)</i>	<i>1-Hour Test</i>	<i>2-Hour Test</i>	<i>3-Hour Test</i>
8	0.50	1.00	1.50
10	0.75	1.30	2.10
12	1.10	2.30	3.40
14	1.40	2.80	4.20
16	1.70	3.30	5.00
18	2.20	4.30	6.50
20	2.80	5.50	8.00

End of Section

INTENTIONALLY LEFT BLANK

SECTION 2 PLAN MODIFICATIONS

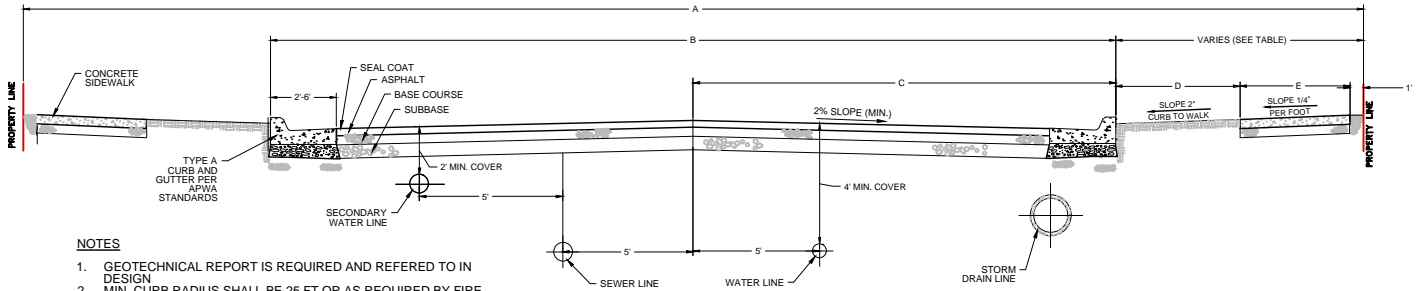

NOTES

1. GEOTECHNICAL REPORT IS REQUIRED AND REFERRED TO IN DESIGN
2. MIN. CURB RADIUS SHALL BE 25 FT OR AS REQUIRED BY FIRE MARSHAL
3. REFER TO TRANSPORTATION MASTER PLAN FOR LANE CONFIGURATION
4. CITY ENGINEER MAY SPECIFY INCREASED MINIMUMS TO PAVEMENT THICKNESS, BASE/SUBBASE, HIGHBACK CURB, ETC. AS NEEDED
5. PRIVATE LANES, ALLEYS, AND RESIDENTIAL DRIVEWAYS CAN NOT CONNECT TO A COLLECTOR OR ARTERIAL

STREET CLASSIFICATION TABLE

STREET CLASSIFICATION	R.O.W. WIDTH (A)	T.B.C. TO T.B.C. (B)	CL TO T.B.C. (C)	PARK STRIP (D)	SIDEWALK (E)
MAJOR COLLECTOR (MEDIAN INCLUDED) SEE FIGURE 1 BELOW	66'	47'	23.5'	4.5'	5'
MINOR COLLECTOR (NO MEDIAN) SEE FIGURE 1 BELOW	66'	47'	23.5'	4.5'	5'
LOCAL*	60'	41'	20.5'	4.5'	5'
LOCAL (32' ASPHALT)**	60'	37'	18.5'	6.5'	5'
PRIVATE ROAD	50'	31'	15.5'	4.5'	5'
ALLEY/PRIVATE LANE	25'	25'	12.5'	-	-

REFER TO WEST POINT TRANSPORTATION MASTER PLAN FOR CLASSIFICATION DIRECTION

- * ALL RESIDENTIAL ROADS REQUIRE ON STREET PARKING
- ** LOCAL (32' ASPHALT) ARE SUBJECT TO THE CRITERIA IN SECTION 10-9A-508 OF THE UTAH STATE CODE

PIPE REQUIREMENTS TABLE

PIPE CLASSIFICATION	MIN SIZE	TYPE	COLOR	APWA
WATER	8"	PVC	BLUE	-
LAND DRAIN	6"	PVC SDR 35	WHITE	--
STORM DRAIN	15"	RCP or DUAL WALL HP POLYPROPYLENE PIPE (for 24" or smaller)	N/A	33 41 00
SEWER	8"	PVC SDR 35	GREEN	33 31 00
SECONDARY WATER	-	-	PURPLE	-

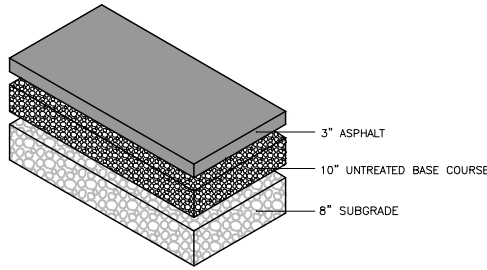

*CITY RESERVES THE RIGHT TO USE THIS SECTION OR REFERENCE SITE SPECIFIC GEOTECH REPORT

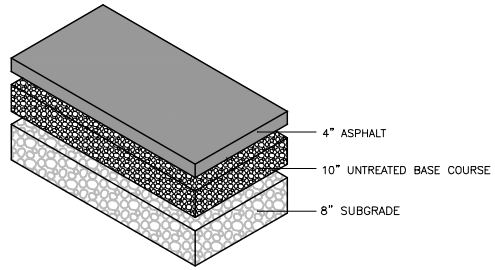

*CITY RESERVES THE RIGHT TO USE THIS SECTION OR REFERENCE SITE SPECIFIC GEOTECH REPORT

A LOCAL/PRIVATE ROAD PAVEMENT SECTION
Scale: (NOT TO SCALE)

B COLLECTOR ROAD PAVEMENT SECTION
Scale: (NOT TO SCALE)

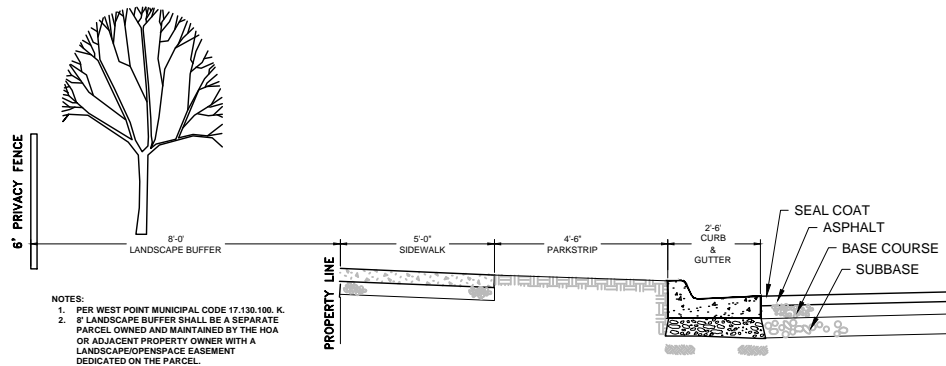

- NOTES:**
1. PER WEST POINT MUNICIPAL CODE 17.130.100. K.
 2. 8' LANDSCAPE BUFFER SHALL BE A SEPARATE PARCEL OWNED AND MAINTAINED BY THE HOA OR ADJACENT PROPERTY OWNER WITH A LANDSCAPE/OPENSPACE EASEMENT DEDICATED ON THE PARCEL.

C FIGURE 1
Scale: (NOT TO SCALE)

1A SUBDIVISION ROAD SECTION

NTS

DRAFTED: LZ	DEVIATIONS FROM STANDARDS MUST BE
DESIGNED: DW	APPROVED BY WEST POINT CITY.
CHECKED: RC	
DATE: 03/2023	
REV	
REV	
REV	



PLAN MODIFICATIONS
WEST POINT CITY

ROAD SECTION - SUBDIVISION ROAD

SHEET 1A

GARDNER ENGINEERING
CIVIL • LAND PLANNING
MUNICIPAL • LAND SURVEYING

1889 W 2100S, WEST HAVEN, UT 84405
P 801.476.0202 F 801.476.0066

R:\West Point\Subdiv\2022 - Update\Project\Subdiv\Plan Modification\Wp - Details - 2023.dwg RD 1 A 1/25/2023 3:29:26 PM ANS eng\A.R.50 (11.00 Inches) 11

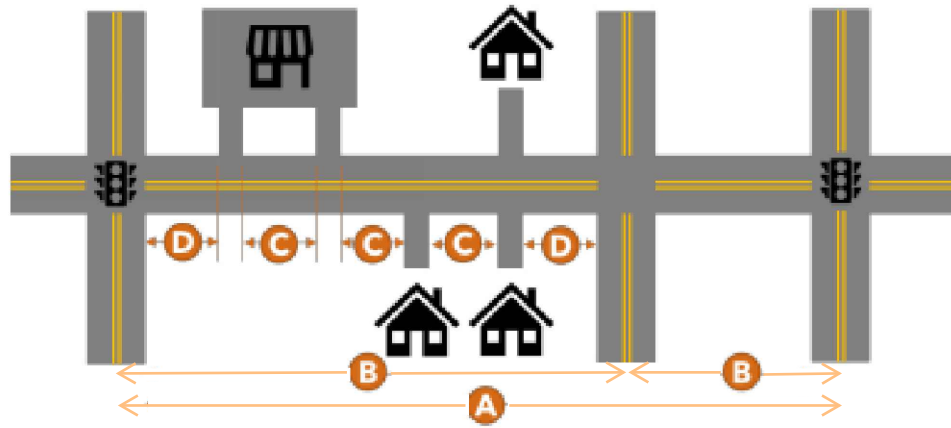

CLASSIFICATION	SIGNAL SPACING (A)	STREET SPACING (B)	DRIVEWAY SPACING (C)	DRIVEWAY SPACING FROM CORNER (D)
MAJOR COLLECTOR	1320 FEET	660 FEET	300 FEET	300 FEET
MINOR COLLECTOR	1320 FEET	330 FEET	150 FEET	150 FEET
LOCAL	N/A	250 FEET	10 FEET	50 FEET
PRIVATE	N/A	250 FEET	10 FEET	50 FEET

NOTES

- STANDARD RESIDENTIAL STREETS SHALL APPROACH THE ARTERIAL OR COLLECTOR STREETS AT AN ANGLE OF NOT LESS THAN 80 DEGREES.
- PRIVATE LANES, ALLEYS, AND DRIVEWAYS SERVING RESIDENTIAL AREAS SHALL NOT CONNECT TO A COLLECTOR OR ARTERIAL STREET. EXCEPTIONS MAY BE GRANTED BY THE PLANNING COMMISSION.
- ALL ACCESS ROADS AND DRIVEWAYS MUST COMPLY WITH THE SPACING STANDARDS. EXCEPTIONS MAY BE GRANTED BY THE PLANNING COMMISSION.
- DRIVEWAY SPACING SHALL NOT APPLY IN THE TURN-AROUND PORTION OF A CUL-DE-SAC NOR IN MULTI-FAMILY DEVELOPMENTS.
- COMBINED DRIVEWAYS THAT SERVE TWO PROPERTIES SHALL BE COUNTED AS ONE DRIVEWAY.
- SPACING SHALL BE MEASURED FROM THE CENTER OF THE RIGHT-OF-WAY FOR STREETS AND FROM THE EDGE OF PAVEMENT FOR DRIVEWAYS.

DRIVEWAY STANDARDS

MINIMUM STANDARDS FOR DRIVEWAYS:

- COMMERCIAL DRIVE WIDTH: 24 FEET MINIMUM, 40 FEET MAXIMUM
- DRIVEWAY ACCESS MAY BE RESTRICTED TO RIGHT-IN / RIGHT-OUT MOVEMENTS ONLY TO ADDRESS SAFETY OR CONGESTION CONCERNS ASSOCIATED WITH THE ACCESS. CONCERNS MAY INCLUDE:
 - DOCUMENTED CRASH HISTORY
 - POOR / LIMITED SIGHT DISTANCE
 - CONGESTION: LOS D OR WORSE EXITING THE DRIVEWAY
 - CONGESTION: LEFT TURN 95TH PERCENTILE QUEUING FROM MAINLINE INTERFERES WITH THROUGH TRAFFIC PROGRESSION ON MAINLINE OR BLOCKS OTHER ROADWAYS / DRIVEWAYS

1B

ACCESS MANAGEMENT

NTS

DRAFTED: LZ	DEVIATIONS FROM STANDARDS MUST BE
DESIGNED: DW	APPROVED BY WEST POINT CITY.
CHECKED: RC	
DATE: 03/2023	
REV	
REV	
REV	



PLAN MODIFICATIONS

WEST POINT CITY

ACCESS MANAGEMENT

SHEET 1B



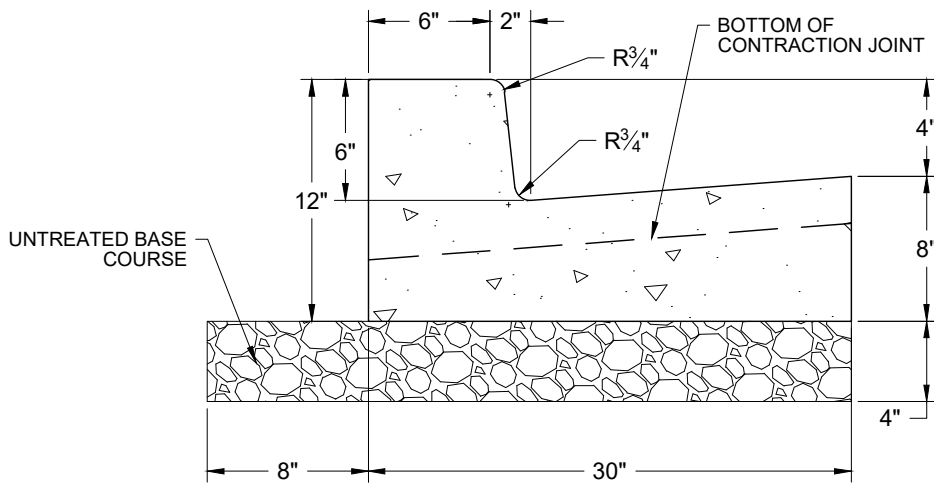

NOTES

1. TYPE A CURB AND GUTTER PER APWA STANDARD DRAWING PLAN NO. N05
2. UNTREATED BASE COURSE MATERIAL SPECIFIED IN APWA SECTION 32 11 23.
3. CLASS 4000 PER APWA SECTION 0330 04
4. DESIGN EXPANSION JOINTS VERTICAL, FULL DEPTH, $\frac{1}{2}$ INCH WIDE WITH TYPE F1 JOINT FILLER MATERIAL PER APWA SECTION 32 12 73.
5. DESIGN CONTRACTION JOINT VERTICAL
6. REINFORCEMENT: ASTM A 615, GRADE 60, GALVANIZED OR EPOXY COATED DEFORMED STEEL PER APWA SECTION 03 20 00

2

TYPE A CURB & GUTTER

NTS

DRAFTED: LZ	DEVIATIONS FROM STANDARDS MUST BE APPROVED BY WEST POINT CITY.
DESIGNED: DW	
CHECKED: RC	
DATE: 03/2023	
REV	
REV	
REV	



PLAN MODIFICATIONS	
WEST POINT CITY	
TYPE A CURB + GUTTER	SHEET 2

GARDNER ENGINEERING
 CIVIL • LAND PLANNING
 MUNICIPAL • LAND SURVEYING
 1580 W 2100S, WEST HAVEN, UT 84405
 P 801.476.0202 F 801.476.0066

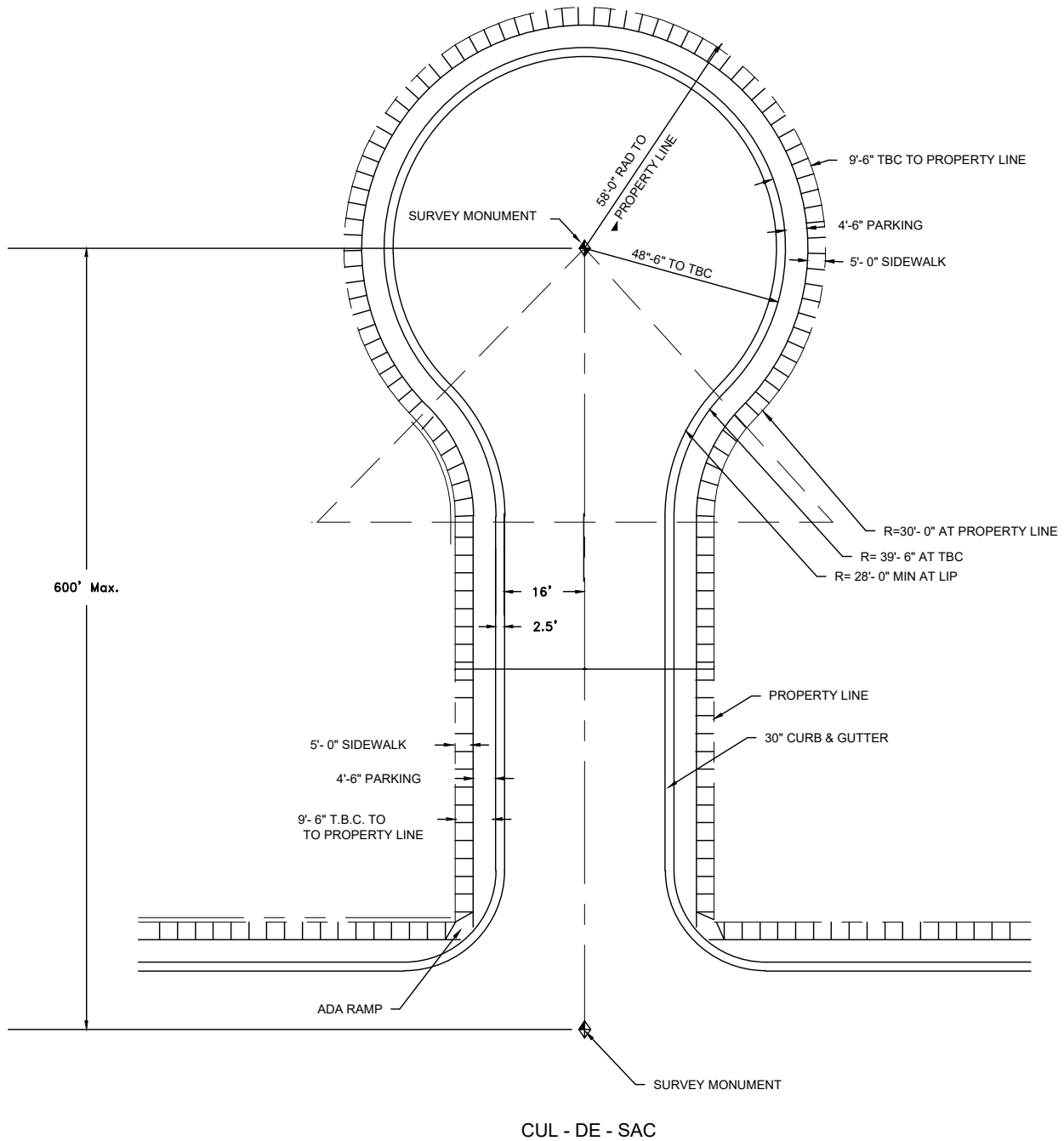

3 CUL-DE-SAC DETAIL

NTS

DRAFTED: LZ	DEVIATIONS FROM STANDARDS MUST BE APPROVED BY WEST POINT CITY.
DESIGNED: DW	
CHECKED: RC	
DATE: 03/2023	
REV	
REV	
REV	



PLAN MODIFICATIONS	
WEST POINT CITY	
CUL-DE-SAC DETAIL	SHEET 3

GARDNER ENGINEERING
 CIVIL • LAND PLANNING
 MUNICIPAL • LAND SURVEYING
 1580 W 2100S, WEST HAVEN, UT 84405
 P 801.476.0202 F 801.476.0066

TABLE OF BEARING AREAS IN SQ. FT FOR CONCRETE THRUST BLOCKING

SIZE	BENDS				TEES*	GATE VALVES	DEAD ENDS	CROSSW/1BRANCH PLUGGED	CROSSW/2 BRAN. PLUGGED
	90°	45°	22 1/2°	11 1/4°					
3	1.0	0.0	0.3	0	0.7	0.5	0.7	0.7	0.7
4	1.8	1.0	0.5	0	1.3	0.5	1.3	1.3	1.3
6	4.0	2.2	1.1	0	2.8	0.7	2.8	2.8	2.8
8	7.1	3.8	2.0	1.0	5.0	2.4	5.0	5.0	5.0
10	11.1	6.0	3.0	1.5	7.8	4.5	7.8	7.8	7.8
12	16.0	8.6	4.4	2.2	11.3	7.3	11.3	11.3	11.3
14	21.7	11.8	6.0	3.0	15.4	11.0	15.4	15.4	15.4
15	25.0	13.5	7.0	3.5	17.6		17.6	17.6	17.6
16	28.4	15.3	8.0	4.0	20.0		20.0	20.0	20.0
18	36.0	19.4	10.0	5.0	25.4		25.4	25.4	25.4
20	44.2	24.0	12.2	6.1	31.4		31.4	31.4	31.4
21	49.0	26.5	13.5	6.8	34.6		34.6	34.6	34.6
22	54.0	29.0	14.8	7.4	38.0		38.0	38.0	38.0
24	64.0	34.5	17.7	8.8	45.0		45.0	45.0	45.0
30	100.0	54.0	27.6	13.8	71.0		71.0	71.0	71.0
36	144.0	78.0	40.0	20.0	102.0		102.0	102.0	102.0

*SIZE IS BRANCH SIZE

FOR 300 P.S.I. INTERNAL STATIC PRESSURE AND 2000 LBS.PER SQ. FT. SOIL BEARING CAPACITY.

*ALL VALVES, TEES, CROSSES AND BENDS SHALL ALSO BE FITTED WITH MECHANICAL RESTRAINTS, SUCH AS MEGA LUG OR ROMA GRIP WITH FLUOROPOLYMER COATED BOLTS AND NUTS.

BEARING AREAS FOR ANY PRESSURE AND SOIL BEARING CAPACITY MAY BE OBTAINED BY MULTIPLYING THE TABULATED VALUES BY A CORRECTION FACTOR "F".

$$F = \frac{\text{ACTUAL SPECIFIED TEST PRESSURE IN HUNDREDS OF LBS/SQ. IN.}}{\text{ACTUAL SOIL BEARING CAPACITY IN THOUSANDS OF LBS.}}$$

EXAMPLE: TO FIND BEARING AREA FOR 8°-90° BEND WITH A STATIC INTERNAL PRESSURE OF 150 P.S.I AND WITH A SOIL BEARING CAPACITY OF 3000 LBS. PE SQ. FT.

$$F = 1.5 / 3 = 0.5 \text{ TABULATED VALUE} = 7.1 \text{ SQ. FT.}$$

$$0.5 \times 7.1 = 3.56 \sim 4 \text{ SQ. FT. (~OR 2FT. LONG BY 2FT. HIGH.)}$$

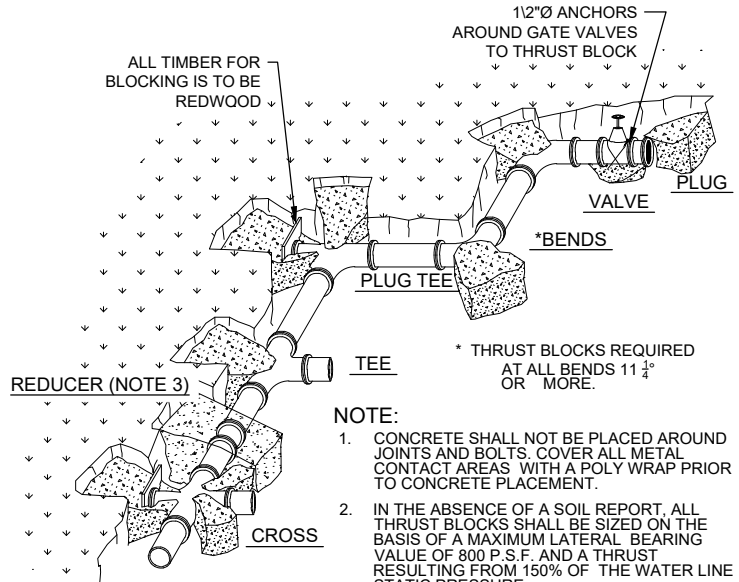

NOTE:

1. CONCRETE SHALL NOT BE PLACED AROUND JOINTS AND BOLTS. COVER ALL METAL CONTACT AREAS WITH A POLY WRAP PRIOR TO CONCRETE PLACEMENT.
2. IN THE ABSENCE OF A SOIL REPORT, ALL THRUST BLOCKS SHALL BE SIZED ON THE BASIS OF A MAXIMUM LATERAL BEARING VALUE OF 800 P.S.F. AND A THRUST RESULTING FROM 150% OF THE WATER LINE STATIC PRESSURE.
3. THRUST BLOCK AT REDUCER SHALL BE KEYED INTO UNDISTURBED TRENCH WALL AND BOTTOM, AND REINFORCED WITH #4 BARS 3" OFF SMALL SIDE FACE. KEY DEPTH = 12" FOR 4"-12" MINUS, AND 18" FOR > 12" MINUS

4

THRUST BLOCK DETAIL

APPLIES TO ALL PRESSURE PIPE

NTS

VALVE LOCATION STANDARD:

AT TEES AND CROSSES, A VALVE SHALL BE INSTALLED IN EACH MAIN LINE, OUT OF THE INTERSECTION, AT THE EXTENSION OF PROPERTY LINES.

AN EXCEPTION TO THE NUMBER OF VALVES MAY BE MADE BY THE CITY WHEN FOLLOWING THE STANDARD WILL PUT MAIN LINE VALVES WITHIN 250' OF EACH OTHER.

AN ISOLATION VALVE SHALL BE INSTALLED IN MAIN LINES ON EACH END OF AN EASEMENT THROUGH PRIVATE PROPERTY.

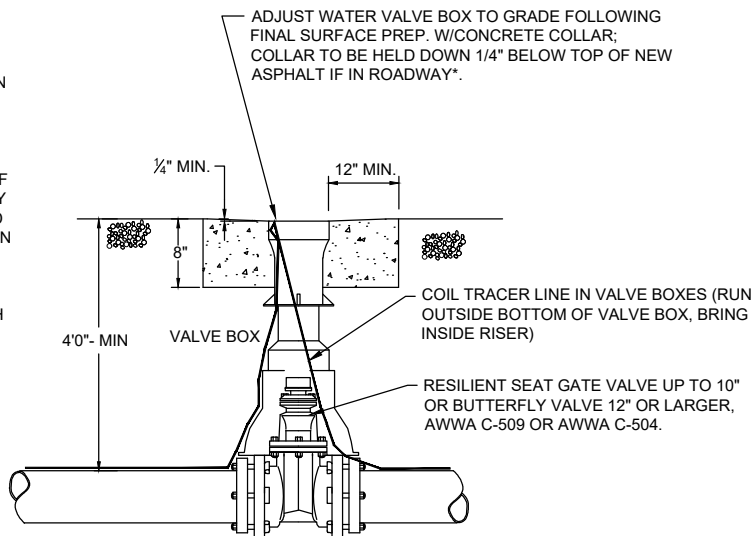

*: VALVE BOX, RISER AND LID MUST COME FROM THE SAME MFR., BE INTENDED FOR USE TOGETHER AND SHALL BE WITHIN PUBLISHED DIMENSION TOLERANCES. IF LOCATED IN ROADWAY W/ SPEED LIMIT OF 40 MPH OR GREATER, LID SHALL BE HEAVY AND EXTRA DEEP.

5

TYPICAL VALVE DETAIL

NTS

DRAFTED: LZ	DEVIATIONS FROM STANDARDS MUST BE APPROVED BY WEST POINT CITY.
DESIGNED: DW	
CHECKED: RC	
DATE: 03/2023	
REV	
REV	
REV	



PLAN MODIFICATIONS	
WEST POINT CITY	
THRUST BLOCK TYPICAL VALVE	SHEET 4

GARDNER ENGINEERING
CIVIL • LAND PLANNING
MUNICIPAL • LAND SURVEYING
1880 W 2100S, WEST HAVEN, UT 84405
P 801.476.0202 F 801.476.0066

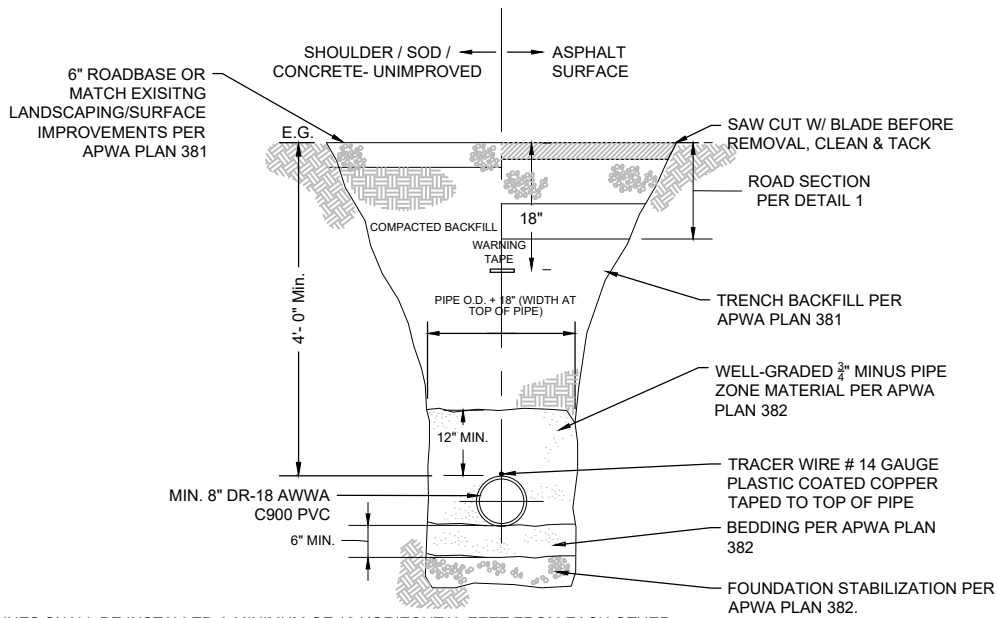

- NOTE:
- WATER & SEWER LINES SHALL BE INSTALLED A MINIMUM OF 10 HORIZONTAL FEET FROM EACH OTHER.
 - WHERE A WATER MAIN AND A SEWER MAIN MUST CROSS, THE WATER MAIN SHALL BE AT LEAST 18" ABOVE THE SEWER MAIN.
 - SEPARATION DISTANCES ARE TO BE MEASURED EDGE-TO-EDGE.
 - WATER MAINS SHALL NOT BE INSTALLED IN THE SAME TRENCH WITH EITHER SEWER OR SECONDARY PIPES.
 - IF THESE STANDARDS CANNOT BE MET, SECURE DIRECTION FROM THE CITY ENGINEER.

6A

TYPICAL TRENCH SECTION

NTS

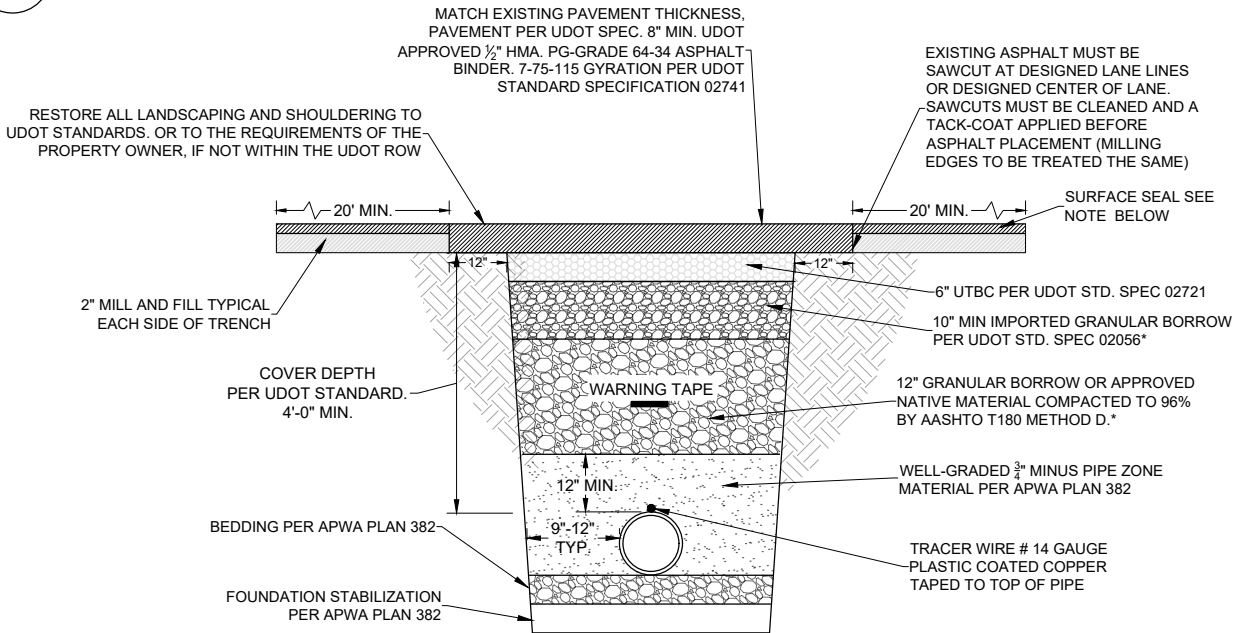

NOTE: **CONTRACTOR SHALL OBTAIN UDOT PERMIT PRIOR COMMENCING WORK**

CHIP SEAL TYPE II WITH EMULSION LMCRS PER UDOT STD. SPEC 02785 (ESTIMATED APPLICATION RATE OF 0.45 GAL/SY) IS REQUIRED FOR THIS ROADWAY ON AT LEAST ALL NEW PAVEMENT PLACED WITHIN THE UDOT RIGHT-OF-WAY.

ALL CONSTRUCTION WITHIN THE UDOT RIGHT-OF-WAY SHALL CONFORM TO THE MOST CURRENT UDOT STANDARD DRAWING AND SPECIFICATIONS.

* FLOWABLE FILL MAY BE REQUIRED BY UDOT PERMIT.

6B

UDOT TRENCH DETAIL

NTS

DRAFTED: LZ	DEVIATIONS FROM STANDARDS MUST BE APPROVED BY WEST POINT CITY.
DESIGNED: DW	
CHECKED: RC	
DATE: 03/2023	
REV	
REV	
REV	



PLAN MODIFICATIONS	
WEST POINT CITY	
TYPICAL TRENCH SECTION	SHEET 5
UDOT CROSSING TRENCH DETAIL	

GARDNER ENGINEERING
 CIVIL • LAND PLANNING
 MUNICIPAL • LAND SURVEYING
 1880 W 2100S, WEST HAVEN, UT 84405
 P 801.476.0202 F 801.476.0066

NOTES:

COPPER SETTER
FORD VBHC72-18W-44-33-Q-NL

ALL COMPRESSION FITTINGS:
SHALL HAVE STAINLESS STEEL INSERTS
FORD 52

AREA SUSCEPTIBLE TO VEHICULAR TRAFFIC:
INSTALL A FLAT METER BOX LID, D+L B-5018.
COLLAR METER BOX WITH A 4' X 4' 3,500 PSI
CONCRETE COLLAR WITH A 4" MIN.
THICKNESS, ON A 6" LAYER OF COMPACTED
ROADBASE.

CORPORATION STOP
FORD FB1100-3x-Q-NL

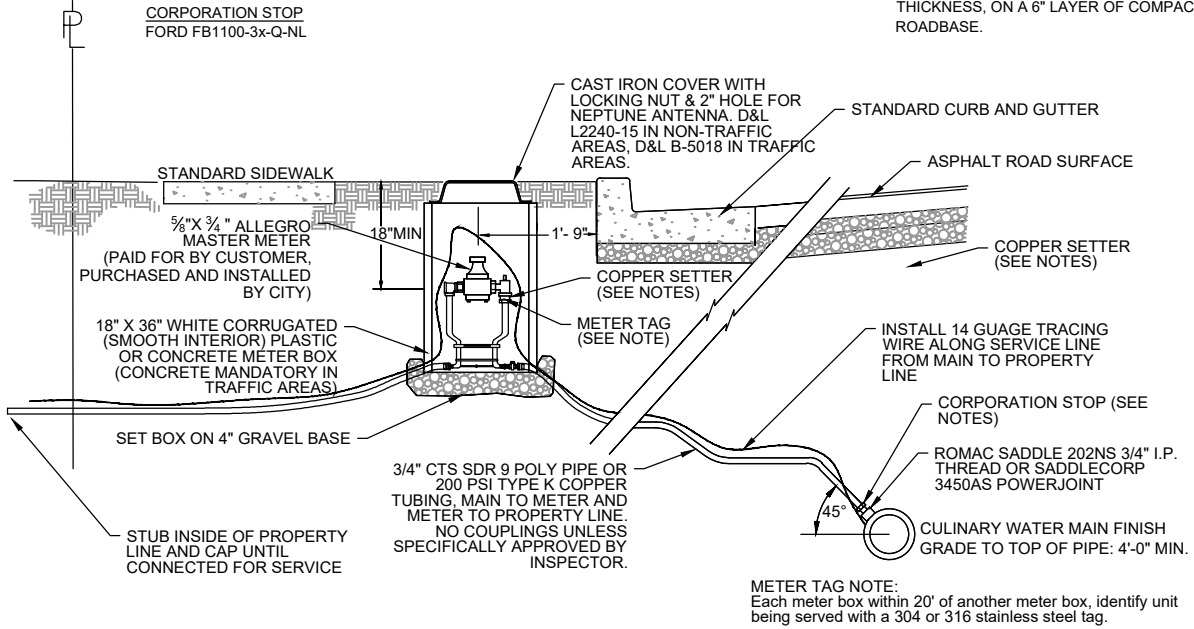

7 TYPICAL WATER CONNECTION\RE-CONNECTION

NTS

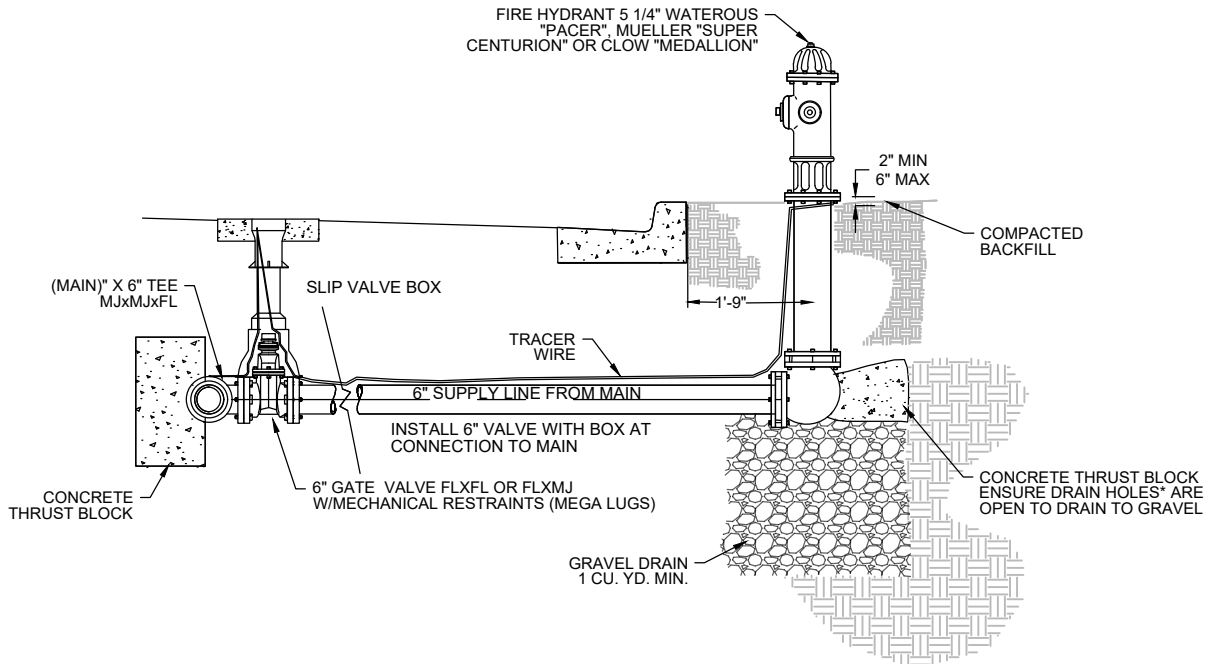

8 FIRE HYDRANT DETAIL

NTS

DRAFTED: LZ	DEVIATIONS FROM STANDARDS MUST BE APPROVED BY WEST POINT CITY.
DESIGNED: DW	
CHECKED: RC	
DATE: 03/2023	
REV	
REV	
REV	



PLAN MODIFICATIONS

WEST POINT CITY

TYPICAL WATER CONNECTION DETAIL
FIRE HYDRANT DETAIL

SHEET 6

CIVIL • LAND PLANNING
MUNICIPAL • LAND SURVEYING

1880 W 2100S, WEST HAVEN, UT 84405
P 801.476.0202 F 801.476.0066

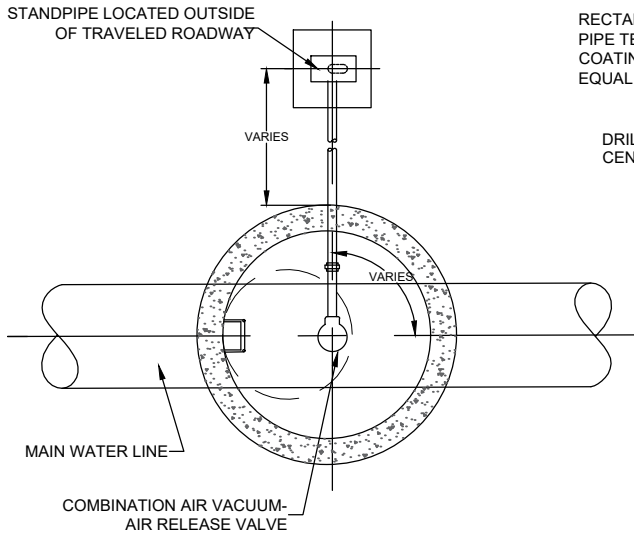

AIR VALVE PLAN VIEW
NTS

RECTANGULAR VENT SHROUD WITH INVERTED PIPE TERMINATION INSIDE, ITEM SP02E BY UTILITY COATINGS AND FABRICATION, INC. OR APPROVED EQUAL. HOT DIP GALVANIZE AFTER FABRICATION

DRILL 1/2" Ø HOLES IN ROWS SPACED ON 2" CENTERS VERTICALLY (TYP. OF 40)

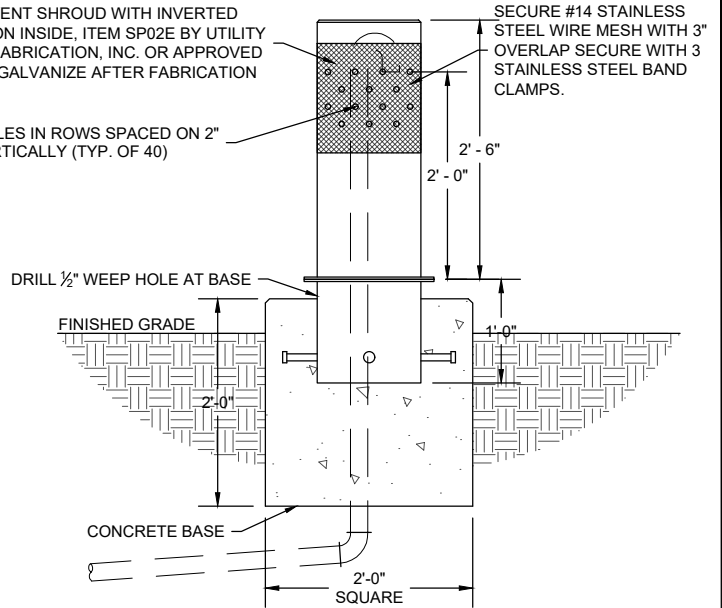

STANDPIPE DETAIL
NTS

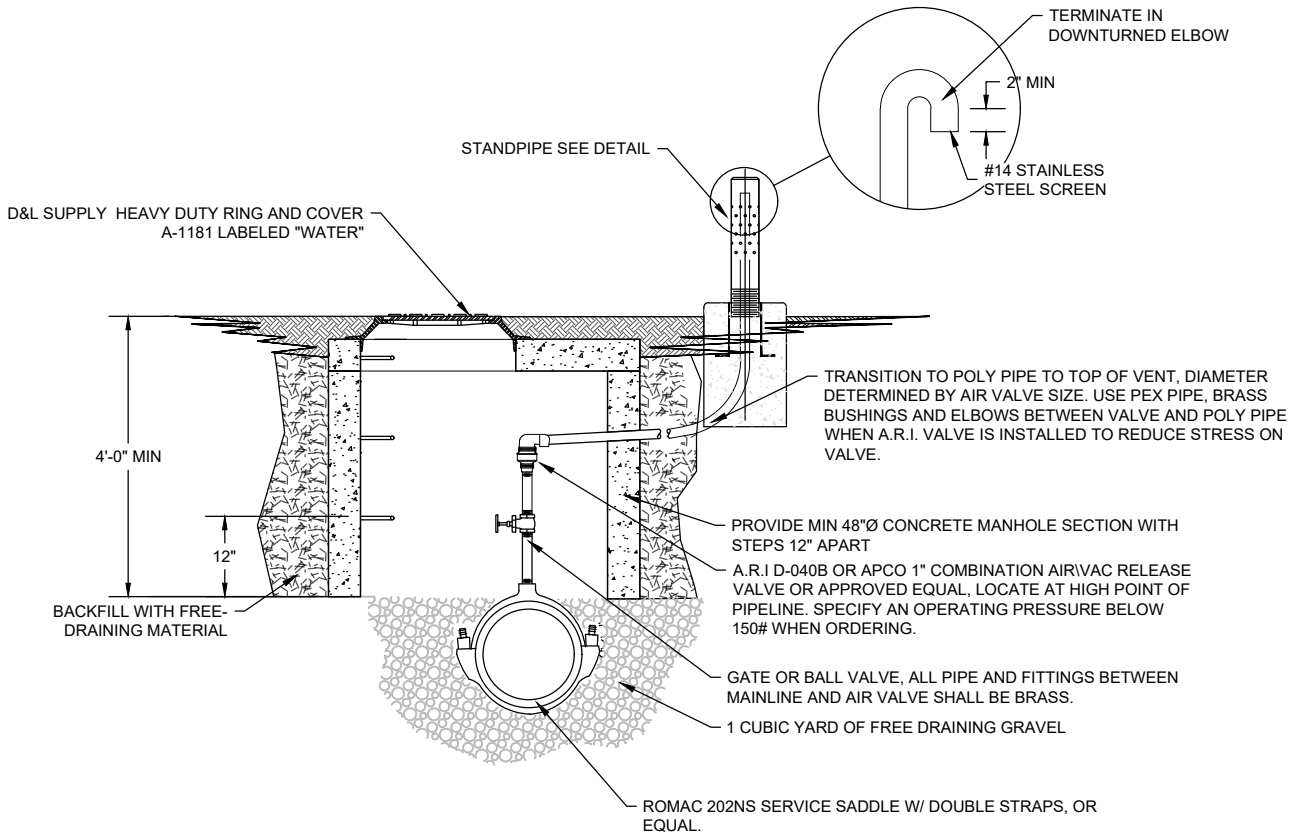

AIR/VAC VALVE DETAIL
NTS

9 COMBINATION AIR/VAC VALVE DETAILS

NTS

DRAFTED: LZ	DEVIATIONS FROM STANDARDS MUST BE APPROVED BY WEST POINT CITY.
DESIGNED: DW	
CHECKED: RC	
DATE: 03/2023	
REV	
REV	
REV	



PLAN MODIFICATIONS	
WEST POINT CITY	
COMBINATION AIR/VAC VALVE DETAIL	SHEET 7

GARDNER ENGINEERING
CIVIL • LAND PLANNING
MUNICIPAL • LAND SURVEYING
1880 W 2100S, WEST HAVEN, UT 84405
P 801.476.0202 F 801.476.0066

NOTE:

WATER MAINS AND SEWER LINES SHALL NOT BE INSTALLED IN THE SAME TRENCH. WHERE LOCAL CONDITIONS MAKE IT IMPOSSIBLE TO INSTALL WATER OR SEWER LINES AT THE SEPARATION DISTANCES REQUIRED ABOVE, AN EXCEPTION TO THE STANDARD MAY BE POSSIBLE. THE ENTITY SEEKING THE EXCEPTION SHALL INITIATE AND PURSUE A REQUEST FOR A SEPARATION EXCEPTION WITH THE STATE DIVISION OF DRINKING WATER, IN ACCORDANCE WITH R309-550-7 OF THE STATE OF UTAH ADMINISTRATIVE RULES.

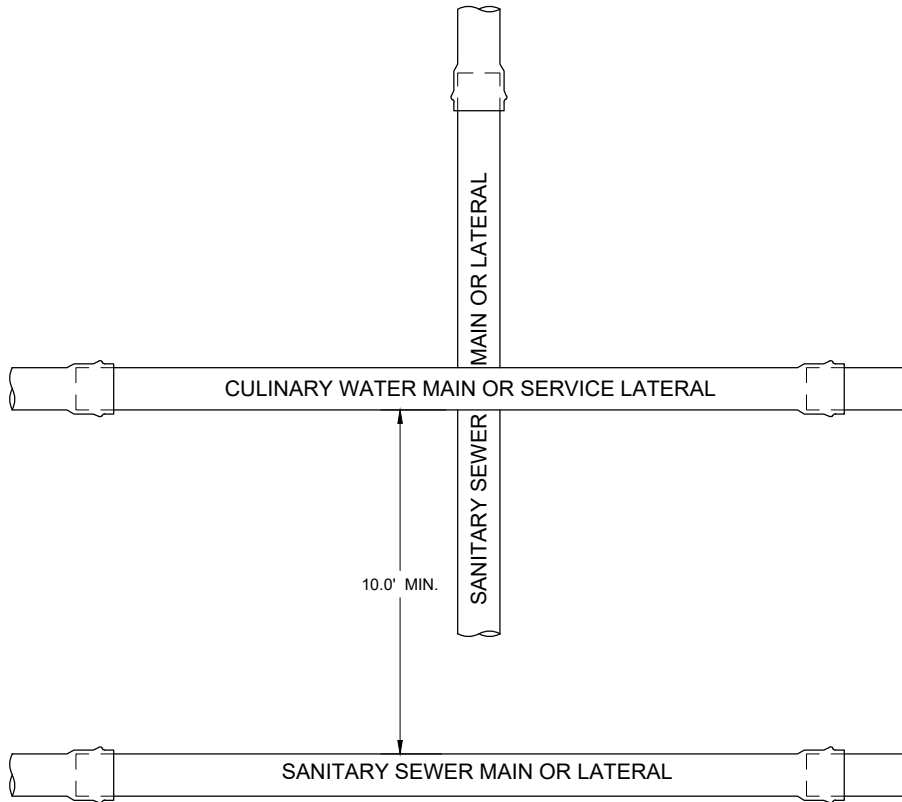

PLAN VIEW

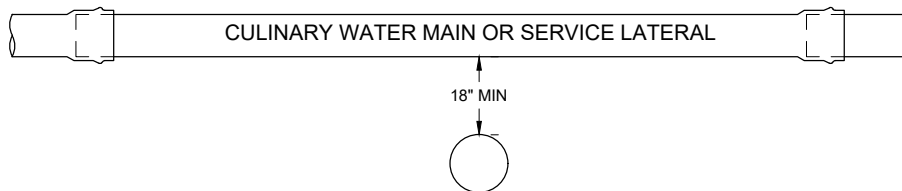

PROFILE VIEW

10 TYPICAL SEWER CROSSING DETAIL

NTS

DRAFTED: LZ	DEVIATIONS FROM STANDARDS MUST BE APPROVED BY WEST POINT CITY.
DESIGNED: DW	
CHECKED: RC	
DATE: 03/2023	
REV	
REV	
REV	



PLAN MODIFICATIONS	
WEST POINT CITY	
TYPICAL SEWER CROSSING	SHEET 8

GARDNER ENGINEERING
 CIVIL • LAND PLANNING
 MUNICIPAL • LAND SURVEYING
 1680 W 2100S, WEST HAVEN, UT 84405
 P 801.476.0202 F 801.476.0066

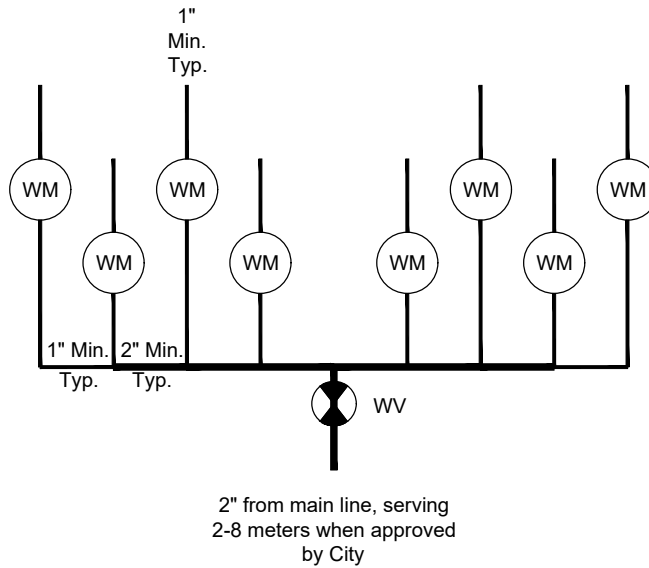

SPECIFICATIONS FOR MULTIPLE METER MANIFOLDS:

1. All piping shall be SDR 9 CTS HDPE or brass.
2. Maintain right angles in piping through use of brass tees, crosses or 90s
3. 2" pipe when more than 1 meter is served, single service size beyond meter determined by home builder.
4. Stagger meter boxes as needed to enable proper compaction
5. Keep meter boxes near roadway
6. No meter boxes in roads or driveways.
7. Mark and wire a waterproof tag to each meter to identify which lot/unit is served by each meter.
8. 2" curb valve and valve box with concrete collar required. Locate in non-traffic area.
9. See also Detail 4 on Sheet 3.

11 MULTIPLE METER MANIFOLD

NTS

DRAFTED: LZ	DEVIATIONS FROM STANDARDS MUST BE APPROVED BY WEST POINT CITY.
DESIGNED: DW	
CHECKED: RC	
DATE: 03/2023	
REV	
REV	
REV	



PLAN MODIFICATIONS	
WEST POINT CITY	
SKEWED SEWER CROSSING	SHEET 9

GARDNER ENGINEERING
 CIVIL • LAND PLANNING
 MUNICIPAL • LAND SURVEYING
 1680 W 2100S, WEST HAVEN, UT 84405
 P 801.476.0202 F 801.476.0066

NOTES:

COPPER SETTER
FORD VBHC74-18W-44-44-Q-NL

CORPORATION STOP
FORD FB1100-4-Q-NL

ALL COMPRESSION FITTINGS:
SHALL HAVE STAINLESS STEEL INSERTS
FORD 52

AREA SUSCEPTIBLE TO VEHICULAR TRAFFIC:
INSTALL A FLAT METER BOX LID, D+L B-5024.
COLLAR METER BOX WITH A 4' X 4' 3,500 PSI
CONCRETE COLLAR WITH A 4" MIN.
THICKNESS OR GREATER TO SATISFY
AUTHORITY HAVING JURISDICTION, ON A 6"
LAYER OF COMPACTED ROADBASE.

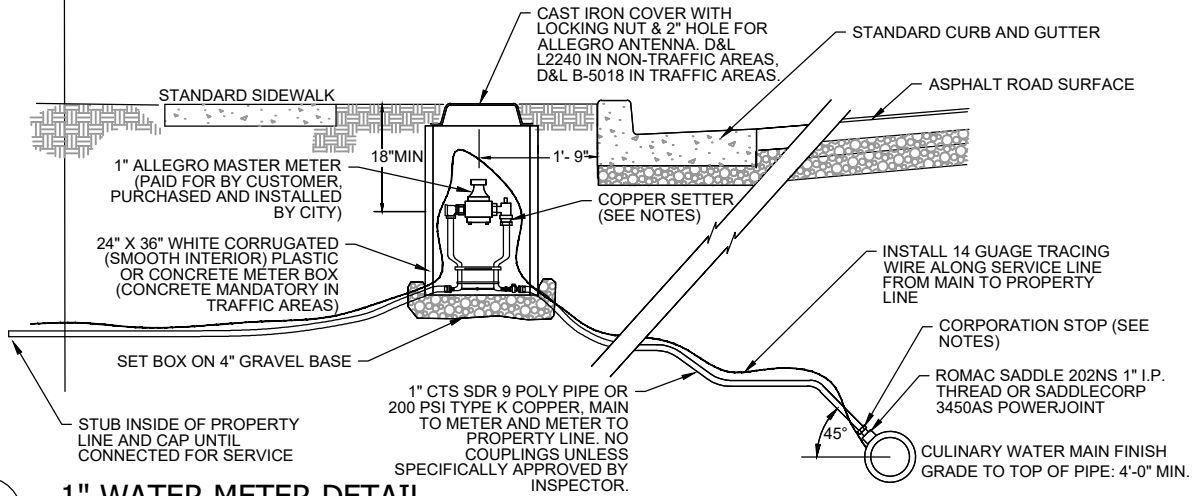

12

1" WATER METER DETAIL

NTS

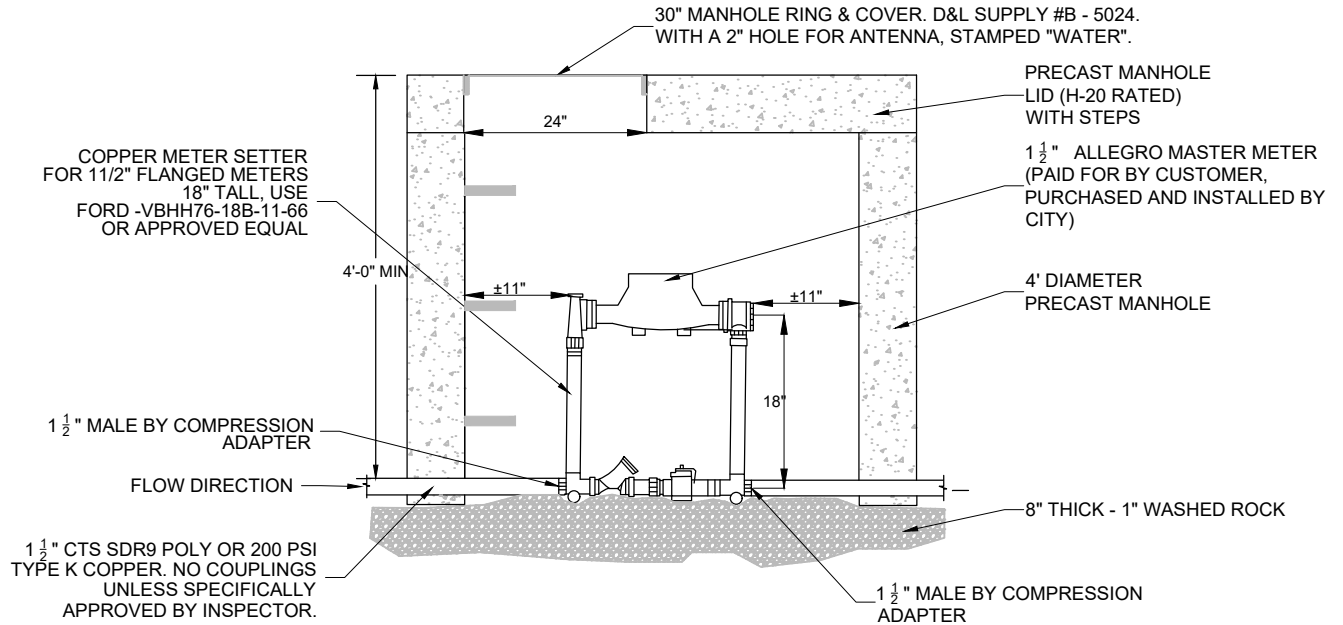

- NOTES:**
- SERVICE LINE COVER UNDER CURB AND GUTTER MUST BE ADJUSTED BETWEEN THE LIMITS OF 36" AND 48". COVER OF SERVICE LINE IN THE STREET MUST NOT BE GREATER THAN 48"
 - DISTRICT MANAGER OR FOREMAN MUST APPROVE LOCATION OF METER BOX IF DISTANCE FROM TOP BACK CURB & GUTTER EXCEEDS 1' -0".
 - METER SETTER, CONSISTS OF 2 DUAL CHECK VALVES, 2 LOCKING KEY VALVES, FITTINGS & SPOOLS, COMPLETE.
 - ALL PIPING, VAULT, & MISCELLANEOUS ITEMS SHALL BE FURNISHED & INSTALLED BY THE CONTRACTOR, COMPLETE. COST OF METER SHALL BE BORNE BY SERVICED CUSTOMER.
 - ANY CHANGES MUST BE APPROVED BY CITY MANAGER OR INSPECTOR.
 - IF SERVICE LINE IS NOT 1 1/2" CTS POLY THEN INSTALLER WILL HAVE TO INSTALL TRANSITION FITTINGS.

13

1 1/2" WATER METER DETAIL

NTS

DRAFTED: LZ	DEVIATIONS FROM STANDARDS MUST BE APPROVED BY WEST POINT CITY.
DESIGNED: DW	
CHECKED: RC	
DATE: 03/2023	
REV	
REV	
REV	



PLAN MODIFICATIONS	
WEST POINT CITY	
1" METER DETAIL	1 1/2" METER DETAIL
	SHEET 10

1880 W 2100S, WEST HAVEN, UT 84405
P 801.476.0202 F 801.476.0066

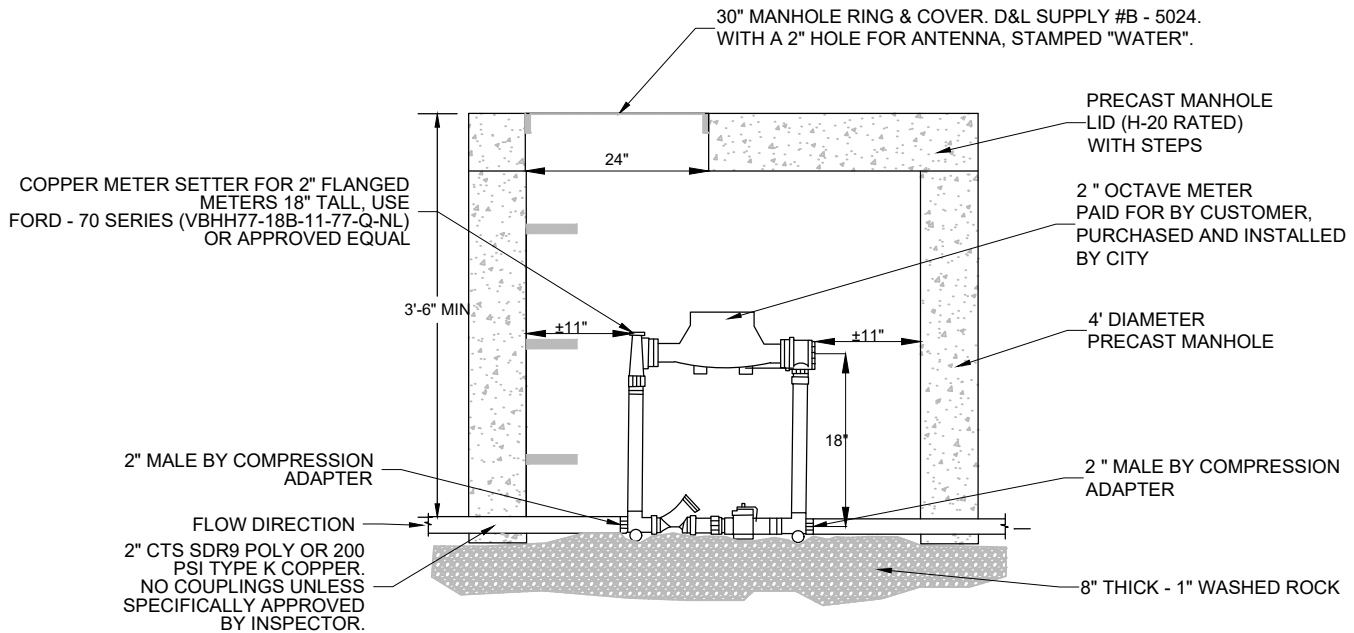

NOTES

1. SERVICE LINE COVER UNDER CURB AND GUTTER MUST BE ADJUSTED BETWEEN THE LIMITS OF 36" AND 48". COVER OF SERVICE LINE IN THE STREET MUST NOT BE GREATER THAN 48"
2. DISTRICT MANAGER OR FOREMAN MUST APPROVE LOCATION OF METER BOX IF DISTANCE FROM TOP BACK CURB & GUTTER EXCEEDS 1' -0".
3. METER SETTER, CONSISTS OF 2 DUAL CHECK VALVES, 2 LOCKING KEY VALVES, FITTINGS & SPOOLS, COMPLETE.
4. ALL PIPING, VAULT, & MISCELLANEOUS ITEMS SHALL BE FURNISHED & INSTALLED BY THE CONTRACTOR, COMPLETE. COST OF METER SHALL BE BORNE BY SERVICED CUSTOMER.
5. ANY CHANGES MUST BE APPROVED BY CITY MANAGER OR INSPECTOR.
6. IF SERVICE LINE IS NOT 2" CTS POLY THEN INSTALLER WILL HAVE TO INSTALL TRANSITION FITTINGS.
7. BACKFLOW PREVENTION DEVICES (REDUCED PRESSURE BACKFLOW PREVENTERS) SHALL BE INSTALLED BY THE DEVELOPER IN ACCORDANCE WITH THE REQUIREMENTS OF THE PLUMBING CODE. SUCH DEVICES MAY BE INSPECTED ANNUALLY BY THE CITY PUBLIC WORKS DEPARTMENT.

14 2" METER DETAIL

NTS

DRAFTED: LZ	DEVIATIONS FROM STANDARDS MUST BE APPROVED BY WEST POINT CITY.
DESIGNED: DW	
CHECKED: RC	
DATE: 03/2023	
REV	
REV	
REV	



PLAN MODIFICATIONS	
WEST POINT CITY	
2" METER DETAIL	SHEET 11

GARDNER ENGINEERING
 CIVIL • LAND PLANNING
 MUNICIPAL • LAND SURVEYING
 1880 W 2100S, WEST HAVEN, UT 84405
 P 801.476.0202 F 801.476.0066

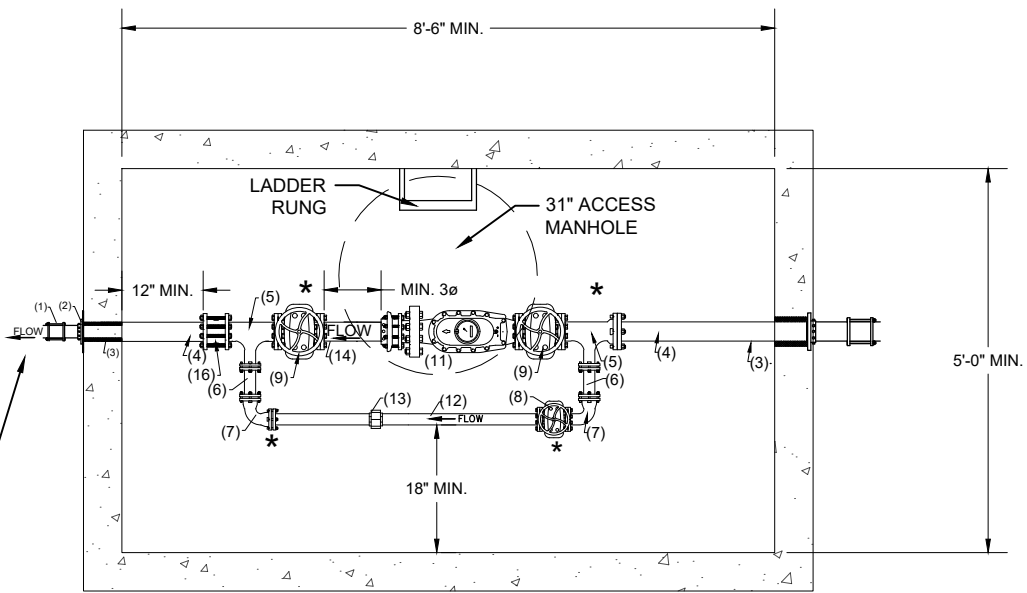

PLAN VIEW

* PIPE STAND LOCATIONS

1/4" THRUST PLATE & FIELD FLANGE

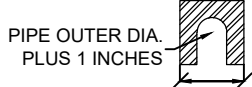

PIPE OUTER DIA. PLUS 1 INCHES

PIPE OUTER DIAMETER PLUS 6" (SQUARE)

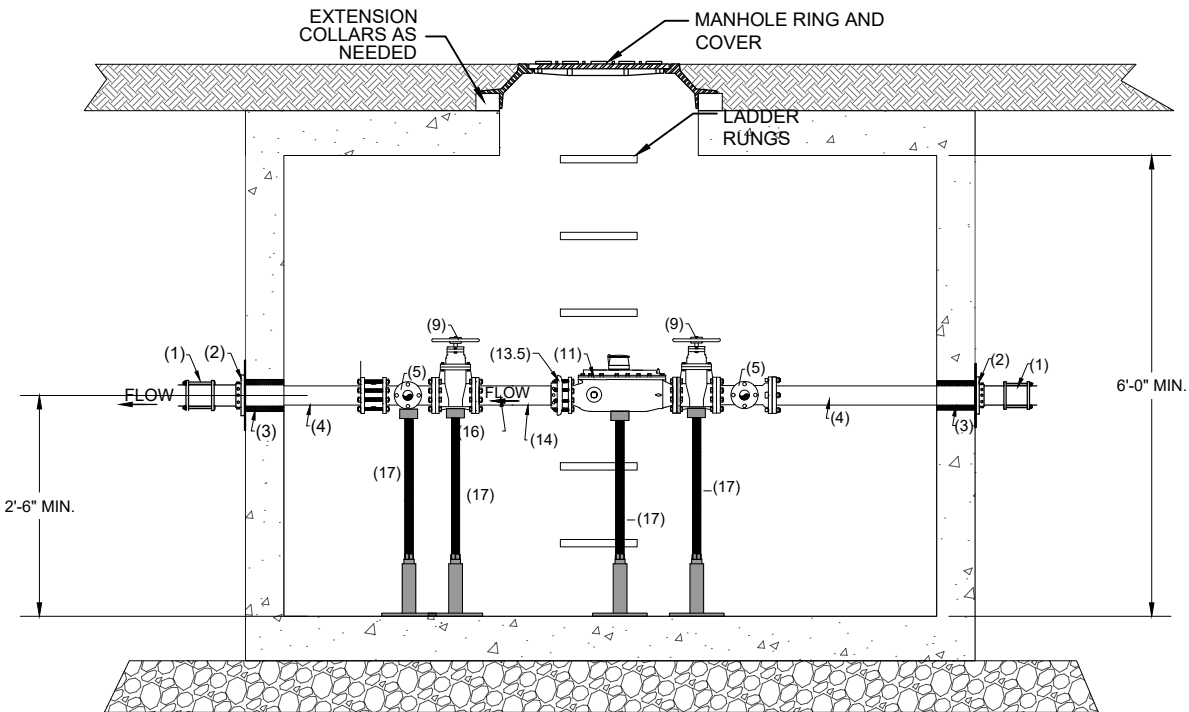

SECTION A-A

15A

3" WATER METER DETAIL

1"=2.5'

DRAFTED: LZ	DEVIATIONS FROM STANDARDS MUST BE APPROVED BY WEST POINT CITY.
DESIGNED: DW	
CHECKED: RC	
DATE: 03/2023	
REV	
REV	
REV	



PLAN MODIFICATIONS	
WEST POINT CITY	
3" WATER METER DETAIL	SHEET12A

GARDNER ENGINEERING
 CIVIL • LAND PLANNING
 MUNICIPAL • LAND SURVEYING
 1680 W 2100S, WEST HAVEN, UT 84405
 P 801.476.0202 F 801.476.0066

Bill of Materials - 3" Meter

#	Qty	Item	Note
1	2	3" COUPLING	
2	2	FIELD FLANGE AND 1/4" STEEL THRUST PLATE	
3	2	CORED HOLE AND GROUT PACK	
4	2	3" PIPE	FIELD MEASURE AND CUT TO FINAL LENGTH
5	2	3" X 2" TEE	
6	2	2" FL X PE PIPE	FIELD MEASURE AND CUT TO FINAL LENGTH, USE DIP OR GSP
7	2	2" 90° ELBOW	END CONNECTIONS AS NEEDED
8	1	2" GATE VALVE WITH HANDWHEEL	PROVIDE A STAINLESS STEEL CHAIN AND BRASS LOCK
9	2	3" GATE VALVE WITH HANDWHEEL	PROVIDE 1 ONLY STAINLESS STEEL CHAIN AND BRASS LOCK
10	1	3" STRAINER	
11	1	3" ULTRASONIC OCTAVE BY MASTER METER	PROVIDE WITH REGISTER AND ANTENNA, ETC.
12	1	2" PIPE	FIELD MEASURE AND CUT TO FINAL LENGTH, USE DIP OR GSP
13	1	2" UNION	FITTING TO PROVIDE EASE OF MAINTENANCE
13.5	1	3" RFCA	
14	1	3" PIPE	FIELD MEASURE AND CUT TO FINAL LENGTH
15	1	INTENTIONALLY BLANK	
16	1	3" CHECK VALVE	VALMATIC WAFER STYLE CHECK VALVE 1400 SERIES OR APPROVED EQUAL
17	4	ADJUSTABLE PIPE STAND	BOLT TO FLOOR WHEN ADJUSTMENTS COMPLETE, USE SS HARDWARE
18	1	CONCRETE UTILITY VAULT WITH RING AND COVER	PRECAST OR CAST IN PLACE VAULT WITH MIN INSIDE DIMENSIONS OF 5' X 10' X 6', H-20 LOADING, WATER TIGHT JOINTS

NOTE:

ALL PIPE AND FITTINGS MUST BE EITHER DUCTILE IRON OR GALVANIZED STEEL FOR POTABLE WATER USE (FOR REFERENCE, PLUMBING AND VAULT ARE SHOWN TO SCALE USING DUCTILE IRON).
ALL CONNECTIONS WITHIN THE VAULT MUST BE RESTRAINED.

BACKFLOW PREVENTION DEVICES (REDUCED PRESSURE BACKFLOW PREVENTERS) SHALL BE INSTALLED BY THE DEVELOPER IN ACCORDANCE WITH THE REQUIREMENTS OF THE PLUMBING CODE. SUCH DEVICES MAY BE INSPECTED ANNUALLY BY THE CITY PUBLIC WORKS DEPARTMENT.

15B

3" WATER METER BOM

NTS

DRAFTED: LZ	DEVIATIONS FROM STANDARDS MUST BE
DESIGNED: DW	APPROVED BY WEST POINT CITY.
CHECKED: RC	
DATE: 03/2023	
REV	
REV	
REV	



PLAN MODIFICATIONS	
WEST POINT CITY	
3" WATER METER BOM	SHEET 12B

GARDNER ENGINEERING
CIVIL • LAND PLANNING
MUNICIPAL • LAND SURVEYING
1880 W 2100S, WEST HAVEN, UT 84405
P 801.476.0202 F 801.476.0066

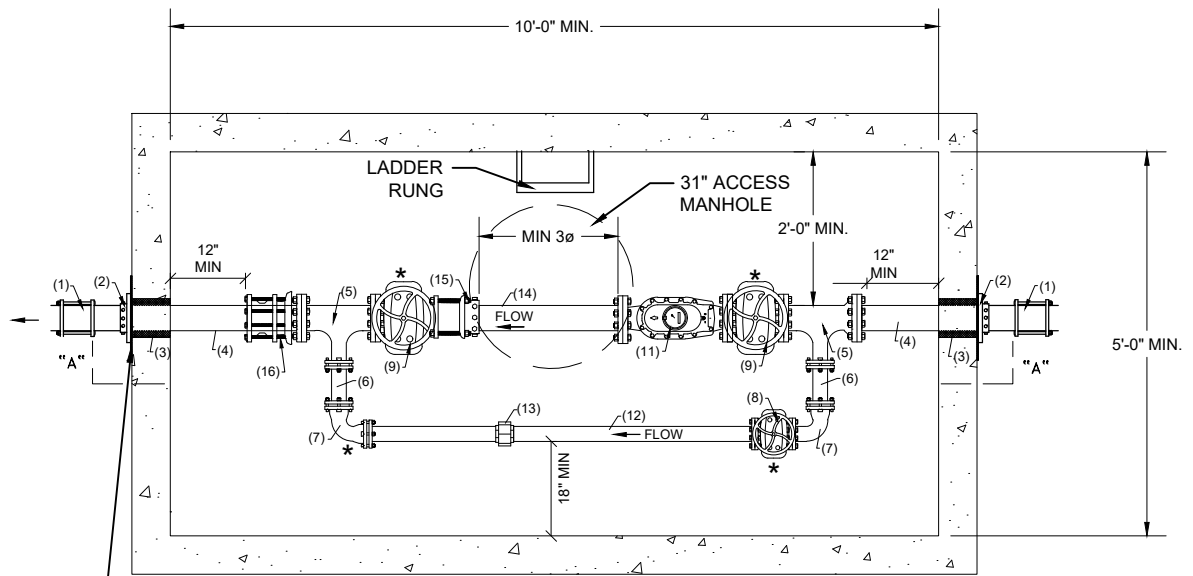

PLAN VIEW

* PIPE STAND LOCATIONS

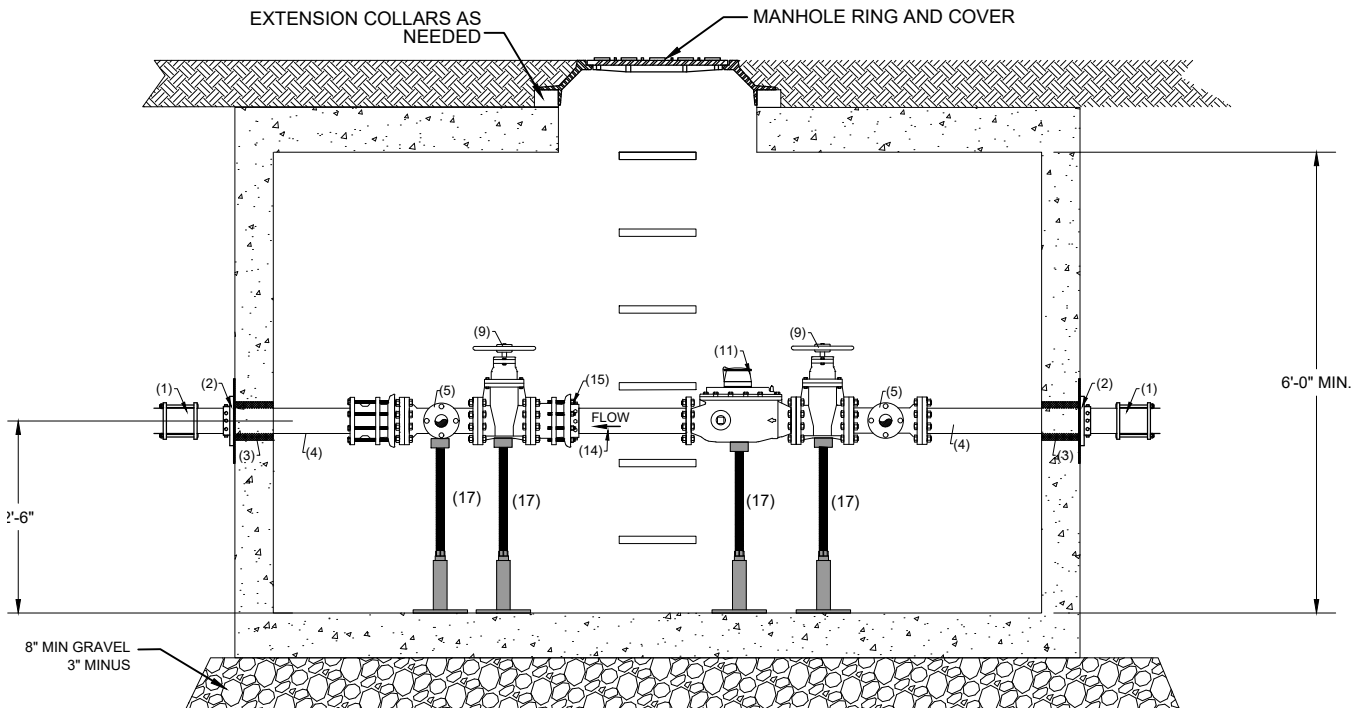
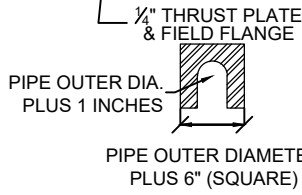

SECTION A-A

16A 4" WATER METER DETAIL

1" = 2.5'

DRAFTED: LZ	DEVIATIONS FROM STANDARDS MUST BE APPROVED BY WEST POINT CITY.
DESIGNED: DW	
CHECKED: RC	
DATE: 03/2023	
REV	
REV	
REV	



PLAN MODIFICATIONS

WEST POINT CITY

4" WATER METER DETAIL

SHEET 13A

GARDNER ENGINEERING
 CIVIL • LAND PLANNING
 MUNICIPAL • LAND SURVEYING
 1680 W 2100S, WEST HAVEN, UT 84405
 P 801.476.0202 F 801.476.0066

Bill of Materials - 4" Meter

#	Qty	Item	Note
1	2	4" COUPLING	
2	2	FIELD FLANGE AND 1/4" STEEL THRUST PLATE	
3	2	CORED HOLE AND GROUT PACK	
4	2	4" FL X PE PIPE	FIELD MEASURE AND CUT TO FINAL LENGTH
5	2	4" X 2" FL TEE	
6	2	2" FL X PE PIPE	FIELD MEASURE AND CUT TO FINAL LENGTH, USE DIP
7	2	2" 90° ELBOW	END CONNECTIONS AS NEEDED
8	1	2" FL GATE VALVE WITH HANDWHEEL	
9	2	4" FL GATE VALVE WITH HANDWHEEL	
10	1	INTENTIONALLY BLANK	
11	1	4" ULTRASONIC OCTAVE BY MASTER METER	PROVIDE WITH REGISTER AND ANTENNA, ETC.
12	1	2" FL X PE PIPE	FIELD MEASURE AND CUT TO FINAL LENGTH, USE DIP
13	1	2" UNION	
14	1	4" FL X PE PIPE	FIELD MEASURE AND CUT TO FINAL LENGTH
15	1	4" RESTRAINED FLANGED COUPLING ADAPTER	
16	1	4" CHECK VALVE	VALMATIC WAFER STYLE CHECK VALVE 1400 SERIES OR APPROVED EQUAL
17	4	ADJUSTABLE PIPE STAND	BOLT TO FLOOR WHEN ADJUSTMENTS COMPLETE, USE SS HARDWARE
18	1	5' X 10' CONCRETE UTILITY VAULT WITH RING AND COVER	AMCOR PRECAST, H-20 LOADING, WATER TIGHT JOINTS

NOTE:

GATE VALVE WITH HANDWHEEL SHALL INCLUDE A STAINLESS STEEL CHAIN AND BRASS LOCK

BACKFLOW PREVENTION DEVICES (REDUCED PRESSURE BACKFLOW PREVENTERS) SHALL BE INSTALLED BY THE DEVELOPER IN ACCORDANCE WITH THE REQUIREMENTS OF THE PLUMBING CODE. SUCH DEVICES MAY BE INSPECTED ANNUALLY BY THE CITY PUBLIC WORKS DEPARTMENT.

16B 4" WATER METER BOM

NTS

DRAFTED: LZ	DEVIATIONS FROM STANDARDS MUST BE APPROVED BY WEST POINT CITY.
DESIGNED: DW	
CHECKED: RC	
DATE: 03/2023	
REV	
REV	
REV	



PLAN MODIFICATIONS	
WEST POINT CITY	
4" WATER METER BOM	SHEET 13B

GARDNER ENGINEERING
 CIVIL • LAND PLANNING
 MUNICIPAL • LAND SURVEYING
 1680 W 2100S, WEST HAVEN, UT 84405
 P 801.476.0202 F 801.476.0066

TRUFLO TF-500 SPEC SHEET

TRUFLO TF-500 BELOW GRADE BLOW-OFF HYDRANT SHALL BE SELF-DRAINING, NON-FREEZING TYPE WITH A DEPTH OF BURY. HYDRANT SHALL BE FURNISHED WITH A 2" VERTICAL (SHOWN) OR HORIZONTAL FIP INLET CONNECTION, A NON-TURNING OPERATING ROD AND SHALL OPEN TO THE LEFT. OUTLET SHALL BE 2" MIP WITH PLUG AND BE HOUSED IN A STANDARD 5-1/4" VALVE BOX.

ALL WATER FLOW SHALL PASS THRU A 2" STEEL PIPE AND CAST LOW LEAD BRASS WATERWAY. THE OPERATING DRIVE MECHANISM SHALL RAISE AND LOWER A PLUNGER TO CONTROL THE FLOW OF WATER AND SHALL BE SERVICEABLE FROM ABOVE GROUND WITH NO DIGGING OR REPLACEMENT NEEDED. SAID OPERATING DRIVE SHALL OPERATE WITH A 3/8" SQUARE DRIVE WRENCH. WHEN OPEN THE FLOW OF WATER SHALL BE UNOBSTRUCTED AND THE DRAIN HOLE SHALL BE COVERED.

HYDRANT SHALL BE SET IN 4 CUBIC FEET OF CRUSHED STONE TO ALLOW FOR PROPER DRAINAGE OF HYDRANT. RECOMMENDATION OF THE AWWA SHOULD BE FOLLOWED WHEN INSTALLING THE HYDRANT.

THE TRUFLO TF-500 BELOW GRADE BLOW-OFF HYDRANT AS MANUFACTURED BY THE KUPFERLE FOUNDRY, ST. LOUIS MO. 63102 OR APPROVED EQUAL.

TRUFLO TF-500 MANUAL BLOW-OFF HYDRANT SHALL BE INSTALLED IN THE FOLLOWING LOCATIONS:

NOTES:

- 1) PIPING BY OTHERS
- 2) KUPFERLE RECOMMENDS USAGE OF A RISER PIPE AND A VALVE WRENCH.

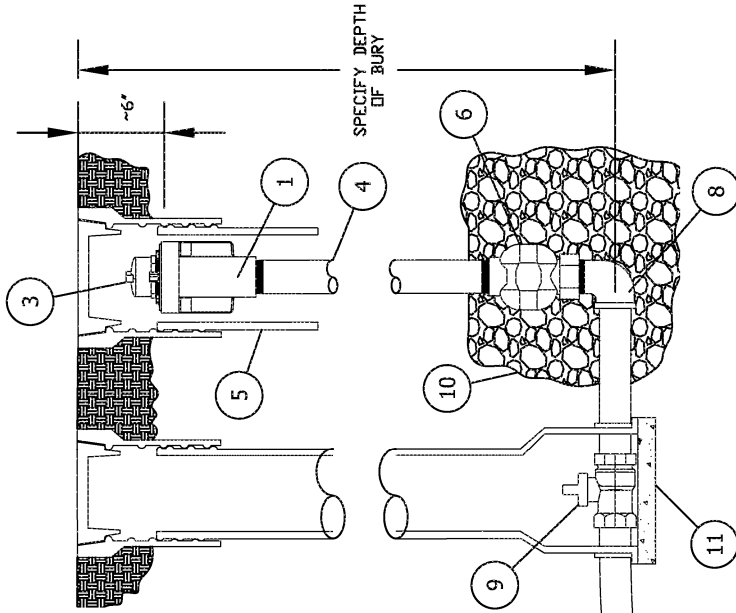

ITEM	ITEM / DESCRIPTION	NOTES
1	TOP CAP	
2	9/16" OPERATING SCREW	
3	2" MIP OUTLET	SHOWN CAPPED
4	2" STEEL PIPE	
5	METER BOX	BY OTHERS
6	INLET VALVE	
7	DRAIN HOLE	
8	90° STREET ELBOW	BY OTHERS
9	HYDRANT SHUT-OFF VALVE	BY OTHERS
10	CRUSHED ROCK	BY OTHERS
11	SOLID CONCRETE BLOCK	BY OTHERS
12	RISER PIPE	OPTIONAL
13	OPERATING SCREW WRENCH	OPTIONAL

INITIALS	DATE
DRAWN DJL	12/11/17
APPROVED DJL	12/11/17
MODIFIED KJW	06/29/21

SCALE
1"=1'-0"

DATE	ISSUED FOR	STATUS / REVISION

2511 NORTH 9TH STREET
ST. LOUIS, MO 63102
1-800-231-3990
FAX 314-231-2820
www.hydrants.com

SHEET 1 OF 1

DRAFTED: LZ	DEVIATIONS FROM STANDARDS MUST BE APPROVED BY WEST POINT CITY.
DESIGNED: DW	
CHECKED: RC	
DATE: 03/2023	
REV	
REV	
REV	



PLAN MODIFICATIONS
WEST POINT CITY
BLOW OFF DETAIL
SHEET 14

1800 W 2100 S, WEST JORDAN, UT 84061
P 801.476.6292 F 801.476.0066

BLOW OFF DETAIL

17

NTS

COVER (MIN.)

LAYTON CANAL	4'-0"
HOOPER CANAL	2'-0"
DAVIS COUNTY DRAIN	4'-0"
UDOT ROAD	SEE TABLE 1

PIPE SIZE

CASING SIZE*

8"	16"
10"	18"
12"	24"
14"	30"
16"-20"	30"

* CASING WALL THICKNESS (0.375") MIN.
 * -METHOD OF INSTALLATION MAY REQUIRE THICKER WALL

MINIMUM DEPTH OF BURY TO TOP OF UTILITY (LONGITUDINAL AND CROSSING INSTALLATIONS)					
LOCATION	UNDER PAVEMENT	UNDER SIDEWALK	UNDER DITCH (NOTE B)	LOCATION < 20 FT FROM EDGE OF PAVEMENT	LOCATION > 20 FT FROM EDGE OF PAVEMENT
DEPTH	4 FT BELOW TOP OF PAVEMENT	3 FT BELOW TOP OF SIDEWALK	3 FT BELOW FLOWLINE	5 FT BELOW NATURAL GRADE	3 FT BELOW NATURAL GRADE

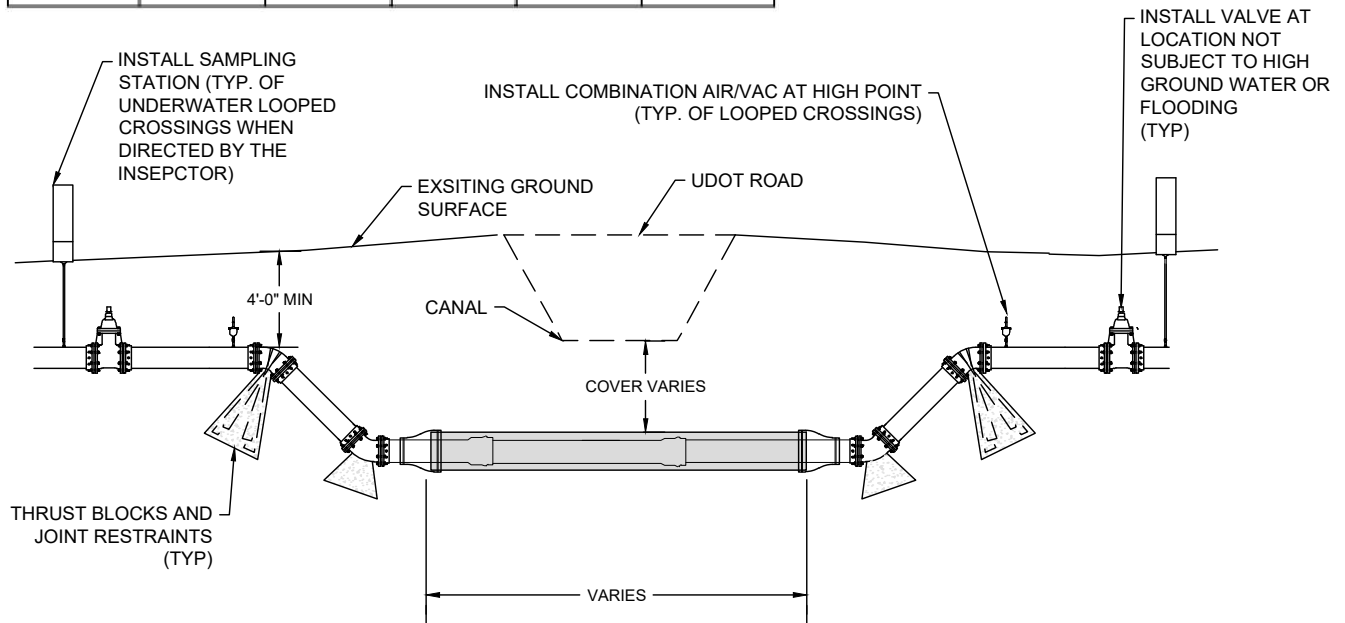

NOTE:

- CASINGS REQUIRE CENTRALIZING SPACERS AND END SEALS W/ S.S. BAND CLAMPS SUBMITTED TO INSPECTOR FOR APPROVAL PRIOR TO INSTALLATION.
- PVC PIPE REQUIRES SELF- RESTRAINING GASKETS ON PIPE JOINTS INSIDE OF CASING AND ONE PIPE JOINT EACH SIDE OF CASING.
- ISOLATION VALVE INSTALLATION IS REQUIRED ON EACH SIDE OF CASING.
- COMBINATION AIR/VAC VALVE INSTALLATION IS REQUIRED ON EACH SIDE OF LOOPED CROSSINGS.
- INSTALLATION OF A SAMPLING TAP OR OTHER ACCEPTABLE MEANS OF SAMPLING WILL BE REQUIRED TO ALLOW FOR REPRESENTATIVE WATER QUALITY TESTING ON THE UPSTREAM AND DOWNSTREAM SIDE OF THE CROSSING IF THE CITY INSPECTOR DETERMINES THAT ANOTHER MEANS OF SAMPLING DOES NOT EXIST NEAR THE GIVEN LOCATION.
- CROSSINGS SHALL BE COMMISSIONED AS AN INTEGRAL PART OF THE SURROUNDING PIPE SYSTEM (FLUSH, DISINFECT, PRESSURE TEST).

18 CANAL/UDOT CROSSING DETAIL

DRAFTED: LZ	DEVIATIONS FROM STANDARDS MUST BE
DESIGNED: DW	APPROVED BY WEST POINT CITY.
CHECKED: RC	
DATE: 03/2023	
REV	
REV	
REV	



PLAN MODIFICATIONS	
WEST POINT CITY	
CANAL/UDOT CROSSING DETAIL	SHEET 15

GARDNER ENGINEERING
 CIVIL • LAND PLANNING
 MUNICIPAL • LAND SURVEYING
 1989 W 2100S, WEST HAVEN, UT 84405
 P 801.476.0202 F 801.476.0066

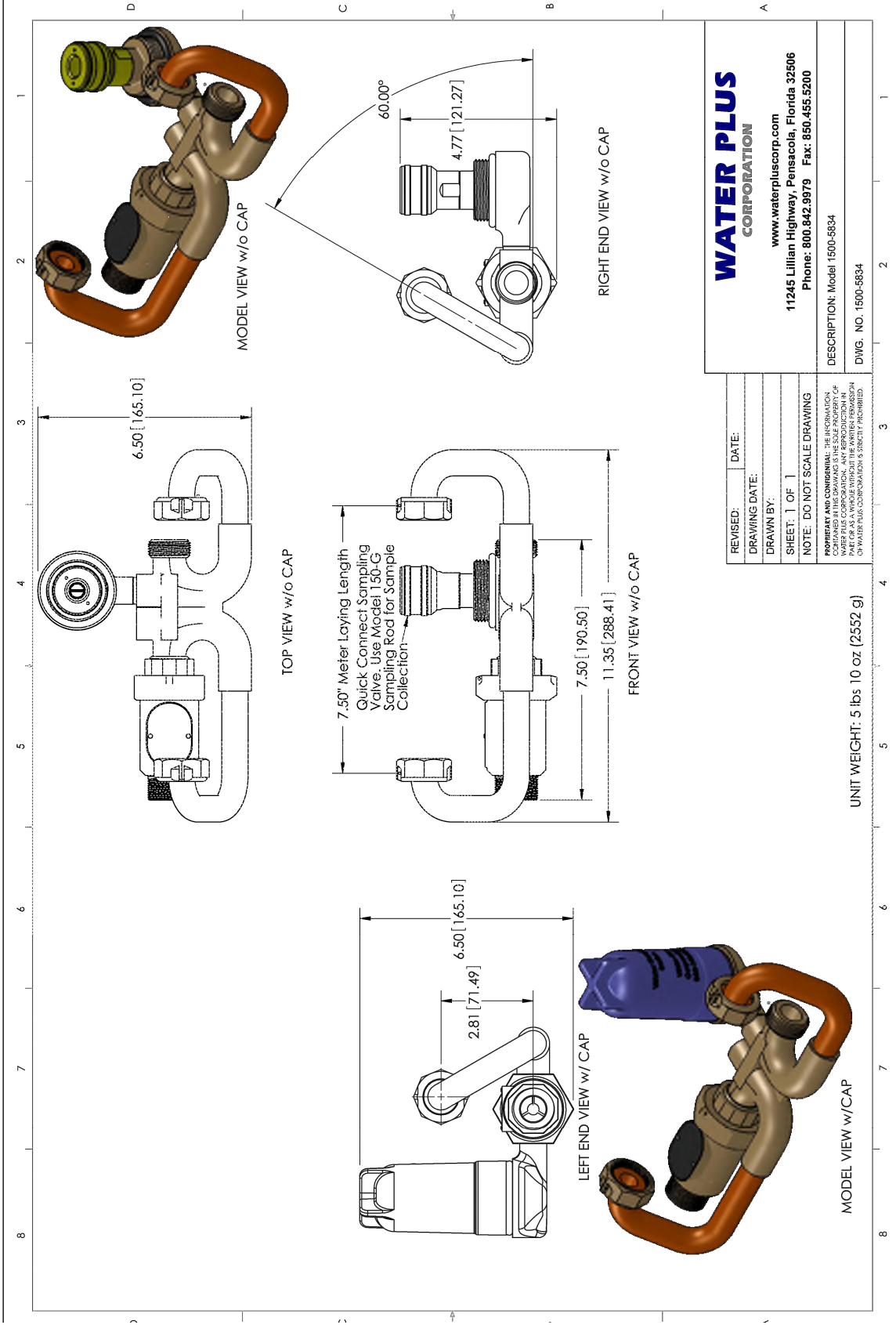

WATER PLUS CORPORATION
 www.waterpluscorp.com
 11245 Lillian Highway, Pensacola, Florida 32506
 Phone: 800.842.9979 Fax: 850.455.5200

DESCRIPTION: Model 1500-5834
 DWG. NO. 1500-5834

REVISED:	DATE:
DRAWING DATE:	
DRAWN BY:	
SHEET: 1 OF 1	
NOTE: DO NOT SCALE DRAWING	
PROPRIETARY AND CONFIDENTIAL: THE INFORMATION CONTAINED IN THIS DRAWING IS THE SOLE PROPERTY OF WATER PLUS CORPORATION. NO PART OF THIS DRAWING OR ANY PART OF A WHOLE WITHOUT THE WRITTEN PERMISSION OF WATER PLUS CORPORATION IS STRICTLY PROHIBITED.	

UNIT WEIGHT: 5 lbs 10 oz (2552 g)

19 SAMPLING STATION DETAIL

DRAFTED: LZ	DEVIATIONS FROM STANDARDS MUST BE APPROVED BY WEST POINT CITY.
DESIGNED: DW	
CHECKED: RC	
DATE: 03/2023	
REV	
REV	
REV	



PLAN MODIFICATIONS
WEST POINT CITY
SAMPLING STATION
SHEET 16

GARDNER ENGINEERING
 CIVIL • LAND PLANNING
 MUNICIPAL • LAND SURVEYING
 1800 W 2100S, WEST HAVEN, UT 84414
 P 801.476.8202 F 801.476.0066

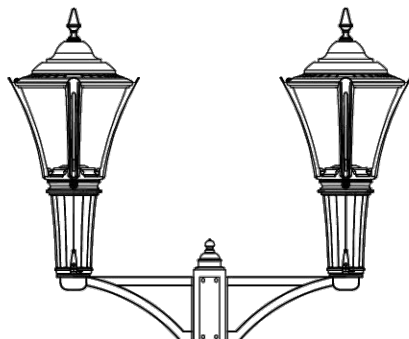

FIXTURE PROVIDED BY STEVENS SALES
MPTR-1914-1675WW-RCD7-TN3-BK
DUAL BRACKET PROVIDED BY STEVENS SALES
HADCO CA4103. TO INCLUDE
GFCI OUTLET

FAWS POSITION	LUMEN MULTIPLIER	SYSTEM WATTAGE
1	.30	.29
2	.50	.50
3	.60	.59
4	.68	.67
5	.77	.76
6	.84	.82
7	.90	.89
8	.94	.93
9	.99	.98
10	1.00	1.00

Factory set to position 10
6,209 STARTING LUMENS

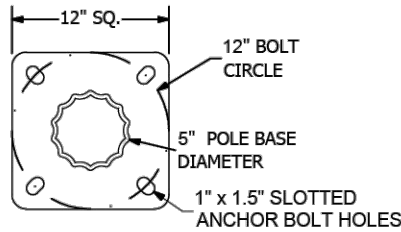
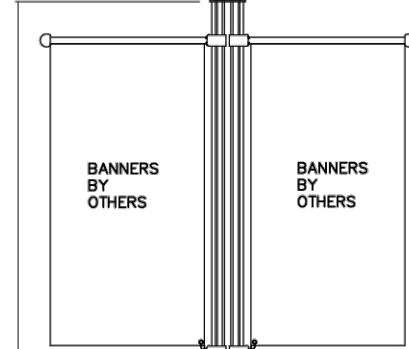

14'

POLE BY STEVENS SALES
14' FLUTED ALUMINUM POLE.

BASE BY STEVENS SALES
2 PIECE CLAM SHELL,
DECORATIVE ALUMINUM
BASE WITH LOGO IN
SANDED ALUMINUM WITH
CLEAR COAT FINISH

25.75"

18"

Hood: Made of die cast A360.1 Aluminum alloy
0.100 (2.5mm) minimum thickness, mechanically
assembled to the cast aluminum heat sink.

Lens: UV-stabilized optical grade lens
with molded micro-optics.

LED Module: Composed of 48 high performance
white LEDs. Color temperature as per
ANSI/NEMA bin Warm White, 3000 Kelvin nominal,
CRI 70 Min. 75 Typical.

Optical System: (LE5, LE3), IES type V, or III.
Edge lit optical system, no substitutions*.
Optical system is rated IP66. 0% uplight
and U0 per IESNA TM 15. Dark sky complaint.

Driver: Electronic driver, Auto adjusting
universal voltage input from 120 to 277

Surge Protector: Surge protector 10kV/10kA.

Lumens: 6,209 lumens in type III, FAWS dial at 10*.

Wattage: Max 75 watts.

FAWS: Field Adjustable Wattage Switch.
No substitutions*

DRAWN BY	CJF
CHECKED BY	CJF
FINISH COLOR	BLACK
KELVIN COLOR	3000K
REVISION	----
DATE	2/20/20



CONTACT: CARSON FILLIN WITH STEVENS SALES COMPANY
CELL: 801-682-5893 EMAIL: CARSON@SSCO.NET
INSIDE SUPPORT: DANA ZAMORA. EMAIL: DANA@SSCO.NET

DWG #(S) R-052318-1S C4103-DWG03

DESC. WEST POINT CITY. LP-1

SHEET
1/1

20

STREET LIGHT 1

STREET LIGHT 1

DRAFTED: LZ	DEVIATIONS FROM STANDARDS MUST BE APPROVED BY WEST POINT CITY.
DESIGNED: DW	
CHECKED: RC	
DATE: 03/2023	
REV	
REV	
REV	



PLAN MODIFICATIONS	
WEST POINT CITY	
STREET LIGHT 1	SHEET 17



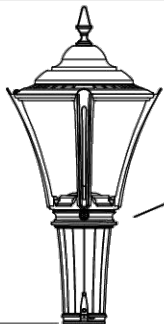

FIXTURE PROVIDED BY STEVENS SALES
MPTR-1914-1675WW-RCD7-TN3-BK

FAWS POSITION	LUMEN MULTIPLIER	SYSTEM WATTAGE
1	.30	.29
2	.50	.50
3	.60	.59
4	.68	.67
5	.77	.76
6	.84	.82
7	.90	.89
8	.94	.93
9	.99	.98
10	1.00	1.00

Factory set to position 10
6,209 STARTING LUMENS

POLE BY STEVENS SALES
14' FLUTED ALUMINUM POLE.

14'

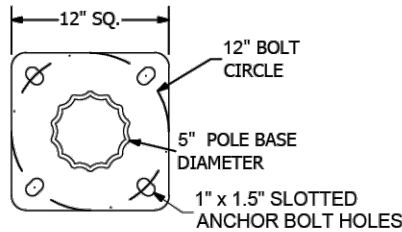

BASE BY STEVENS SALES
2 PIECE CLAM SHELL,
DECORATIVE ALUMINUM
BASE WITH LOGO IN
SANDED ALUMINUM WITH
CLEAR COAT FINISH

25.75"

18"

Hood: Made of die cast A360.1 Aluminum alloy
0.100 (2.5mm) minimum thickness, mechanically
assembled to the cast aluminum heat sink.

Lens: UV-stabilized optical grade lens
with molded micro-optics.

LED Module: Composed of 48 high performance
white LEDs. Color temperature as per
ANSI/NEMA bin Warm White, 3000 Kelvin nominal,
CRI 70 Min. 75 Typical.

Optical System: (LE5, LE3), IES type V, or III.
Edge lit optical system, no substitutions*.
Optical system is rated IP66. 0% uplight
and U0 per IESNA TM 15. Dark sky complaint.

Driver: Electronic driver, Auto adjusting
universal voltage input from 120 to 277

Surge Protector: Surge protector 10kV/10kA.

Lumens: 6,209 lumens in type III, FAWS dial at 10*.

Wattage: Max 75 watts.

FAWS: Field Adjustable Wattage Switch.
No substitutions*

Photocell Receptacle: 7 pin.

DRAWN BY	CJF	SSCO EST. 1914 Stevens Sales Company
CHECKED BY	CJF	
FINISH COLOR	BLACK	
KELVIN COLOR	3000K	
REVISION	----	
DATE	2/20/20	

CONTACT: CARSON FILLIN WITH STEVENS SALES COMPANY
CELL: 801-682-5893 EMAIL: CARSON@SSCO.NET
INSIDE SUPPORT: DANA ZAMORA. EMAIL: DANA@SSCO.NET

DWG #(S) R-1254041218-3S

DESC. WEST POINT CITY. LP-2

SHEET
1/1

21

STREET LIGHT 2

NTS

DRAFTED: LZ	DEVIATIONS FROM STANDARDS MUST BE
DESIGNED: DW	APPROVED BY WEST POINT CITY.
CHECKED: RC	
DATE: 03/2023	
REV	
REV	
REV	



PLAN MODIFICATIONS

WEST POINT CITY

STREET LIGHT 2

SHEET 18

GARDNER ENGINEERING
CIVIL • LAND PLANNING
MUNICIPAL • LAND SURVEYING
1889 W 2100S, WEST HAVEN, UT 84405
P 801.476.0202 F 801.476.0066

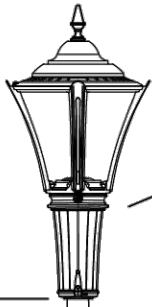

FIXTURE PROVIDED BY STEVENS SALES
MPTR-1914-1675WW-RCD7-TN3-BK

12'

FAWS POSITION	LUMEN MULTIPLIER	SYSTEM WATTAGE
1	.30	.29
2	.50	.50
3	.60	.59
4	.68	.67
5	.77	.76
6	.84	.82
7	.90	.89
8	.94	.93
9	.99	.98
10	1.00	1.00

POLE BY STEVENS SALES
12' TAPERED STEEL POLE
DIRECT BURIAL (16' OVERALL
HEIGHT)

26"
BASE BY STEVENS SALES
2 PIECE CLAM SHELL,
DECORATIVE ALUMINUM
BASE WITH LOGO IN
SANDED ALUMINUM WITH
CLEAR COAT FINISH

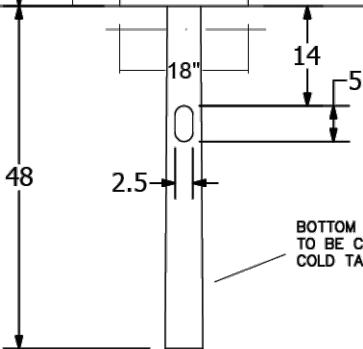

BOTTOM 4' OF POLE
TO BE COVERED IN
COLD TAR EPOXY

Hood: Made of die cast A360.1 Aluminum alloy
0.100 (2.5mm) minimum thickness, mechanically
assembled to the cast aluminum heat sink.

Lens: UV-stabilized optical grade lens
with molded micro-optics.

LED Module: Composed of 48 high performance
white LEDs. Color temperature as per
ANSI/NEMA bin Warm White, 3000 Kelvin nominal,
CRI 70 Min. 75 Typical.

Optical System: (LE5, LE3), IES type V, or III.
Edge lit optical system, no substitutions*.
Optical system is rated IP66. 0% uplight
and U0 per IESNA TM 15. Dark sky complaint.

Driver: Electronic driver, Auto adjusting
universal voltage input from 120 to 277

Surge Protector: Surge protector 10kV/10kA.

Lumens: 6,209 lumens in type III, FAWS dial at 10*.

Wattage: Max 75 watts.

FAWS: Field Adjustable Wattage Switch.
No substitutions*

Photocell Receptacle: 7 pin.

DRAWN BY	CJF
CHECKED BY	CJF
FINISH COLOR	BLACK
KELVIN COLOR	3000K
REVISION	----
DATE	2/20/20



CONTACT: CARSON FILLIN WITH STEVENS SALES COMPANY
CELL: 801-682-5893 EMAIL: CARSON@SSCO.NET
INSIDE SUPPORT: DANA ZAMORA. EMAIL: DANA@SSCO.NET

DWG #(S)	R-052318-2S
DESC.	WEST POINT CITY. LP-3
SHEET	1/1

22 STREET LIGHT 3

NTS

DRAFTED: LZ	DEVIATIONS FROM STANDARDS MUST BE
DESIGNED: DW	APPROVED BY WEST POINT CITY.
CHECKED: RC	
DATE: 03/2023	
REV	
REV	
REV	



PLAN MODIFICATIONS
WEST POINT CITY
STREET LIGHT 3
SHEET 19



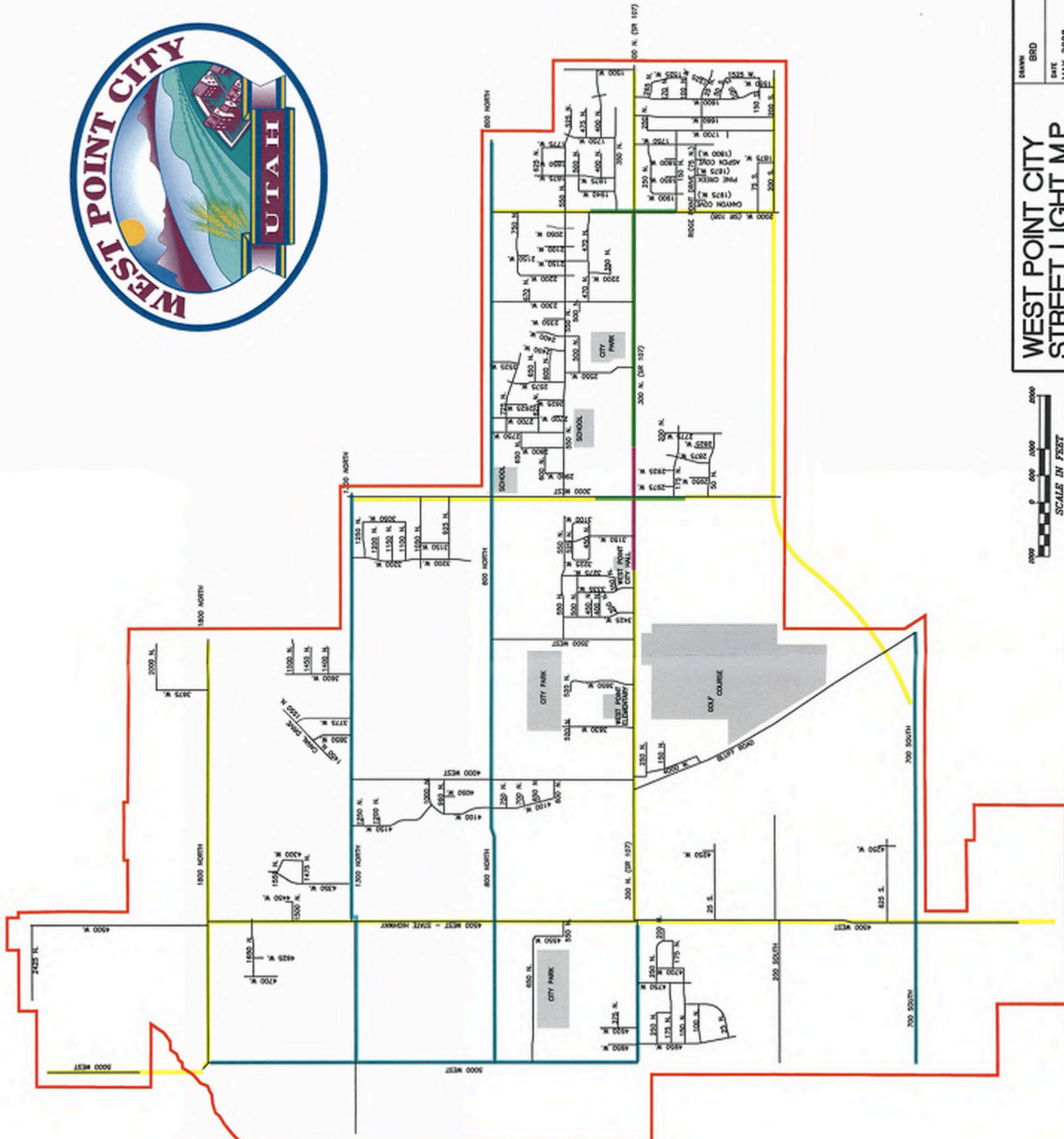

STREET LIGHT LEGEND

- DOWNTOWN - LP1 - 150' SPACING
- CENTRAL BUSINESS DISTRICT - LP1 - 200' SPACING
- ARTERIALS - LP2 - 200' SPACING
- COLLECTORS - LP2 - 330' SPACING
- RESIDENTIAL - LP3 - 660' SPACING



DRAWN BRD		CHECKED JCA	DRAWING NUMBER
DATE MAY 2008		APPROVED	FILE NUMBER
WEST POINT CITY STREET LIGHT M.P.			



NOTE

- REFER TO APWA PLAN 292

24

STREET SIGN

NTS

DRAFTED: LZ	DEVIATIONS FROM STANDARDS MUST BE
DESIGNED: DW	APPROVED BY WEST POINT CITY.
CHECKED: RC	
DATE: 03/2023	
REV	
REV	
REV	



PLAN MODIFICATIONS	
WEST POINT CITY	
STREET SIGN STANDARD	SHEET 21

GARDNER ENGINEERING
 CIVIL • LAND PLANNING
 MUNICIPAL • LAND SURVEYING
 1989 W 2100S, WEST HAVEN, UT 84405
 P 801.476.0202 F 801.476.0066